

NAME	Hiroyoshi Ishikawa	TEMP	20 °C	ENGINE	GS15R	MUFFLER	39012	MANIFOLD	39013
DATA	2003. 12. 7	HUMIDITY	50 %	HEAD CLEARANCE	0. 2 mm	FUEL TYPE	BP PEAK POWER		
TRACK	KYOSHO CIRCUIT	TRACTION	80 %	PLUG No.	GS	RADIO	FUTABA 3PJ SUPER		

FRONT

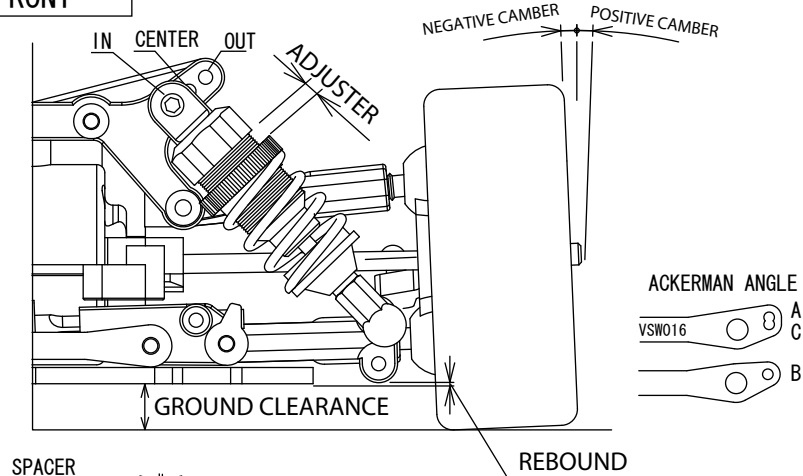

CASTER	ANGLE
2mm	10°
1mm	8°
0mm	6°

DIFF.	4 Bevel
DIFF OIL	# 30,000
ACKERMEN ANGLE	A (B) C
ST D/R	%

SHOCK OIL	300 350 (400) 450 500 550 600 700
SHOCK PISTON	Pure Kit
SPRING	S (B) G Long VZ073-4016
SPRING ADJUSTER	4 mm
SHOCK POS	IN (CENTER) OUT
CASTER ANGLE	2 mm
CAMBER ANGLE	OG / (1G) 0 0.5 (1.0) 1.5 2.0
TOE ANGLE	Out 1°
FRONT WIDTH	198 mm
REBOUND STOP	0 mm
STABILIZER BAR	
TIRE TYPE	V Slick 30
TIRE SIZE	No. 92013
WHEEL	No. 92012
GROUND CLEARANCE	5.5 mm
RING GEAR	(39T) 40T

REAR

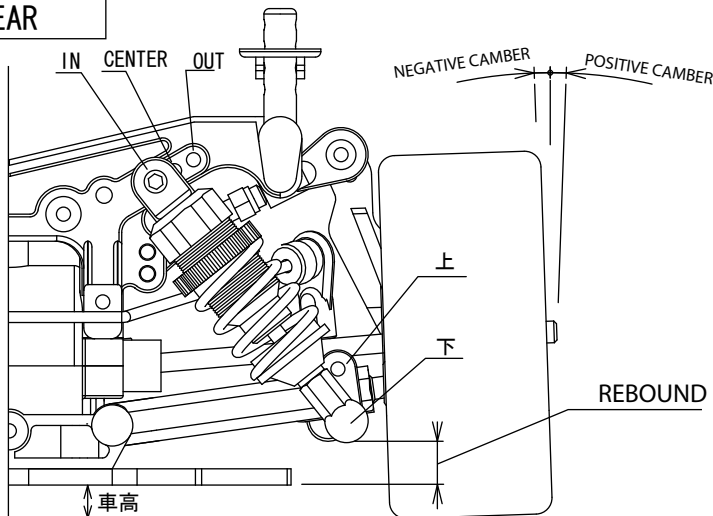

RING GEAR 39T					
GEAR	TOTAL	GEAR	TOTAL	GEAR	TOTAL
20	50	7.50	25	45	5.40
20	51	7.65	25	46	5.52
21	50	7.14	26	45	5.19
21	51	7.28	26	46	5.30
22	50	6.81	27	45	5.00
22	51	6.95	27	46	5.11

RING GEAR 40T					
GEAR	TOTAL	GEAR	TOTAL	GEAR	TOTAL
20	50	7.69	25	45	5.54
20	51	7.85	25	46	5.66
21	50	7.33	26	45	5.33
21	51	7.47	26	46	5.44
22	50	6.99	27	45	5.13
22	51	7.13	27	46	5.24

SHOCK OIL	300 350 (400) 450 500 550 600 700
SHOCK PISTON	Pure Kit
SPRING	S (B) G Pure Kit
SPRING ADJUSTER	4.5 mm
SHOCK POS	IN (CENTER) OUT
SHOCK POS	U / (L)
UPPER ARM POS	IN (U/L) - OUT (U/L)
CAMBER ANGLE	OG / (1G) 0 0.5 1.0 1.5 (2.0) 2.5 3.0
TOE ANGLE	One Side 3°
REAR WIDTH	199 mm
REBOUND STOP	+ 4.0 mm
STABILIZER BAR	SILVER (BLACK) GOLD
REAR SUS. HOLDER	(H) L
DIFF OIL	# 5,000
TIRE TYPE	V Slick 30
TIRE SIZE	No. 92013
WHEEL	No. 92012
GROUND CLEARANCE	6 mm
BODY	ASTRA
GEAR	17T
GEAR	39T
RING GEAR	(39T) 40T
CLUCH SHOE	UM210
CLUCH SPRING	No. 92741

memo.
W6007