

# V-ONE rrr Shimo EDITION

# SETTING DATA Ver 1.01

Name	Takaaki Shimo	Temp	°C	Engine	OS 12XZ II	Muffler	OS 1060
Date	2010.04	Humidity	%	Head Clearance	mm	Fuel Type	
Track	GULF COAST	Traction	%	Plug No.	RP6	Radio	Futaba 4PK

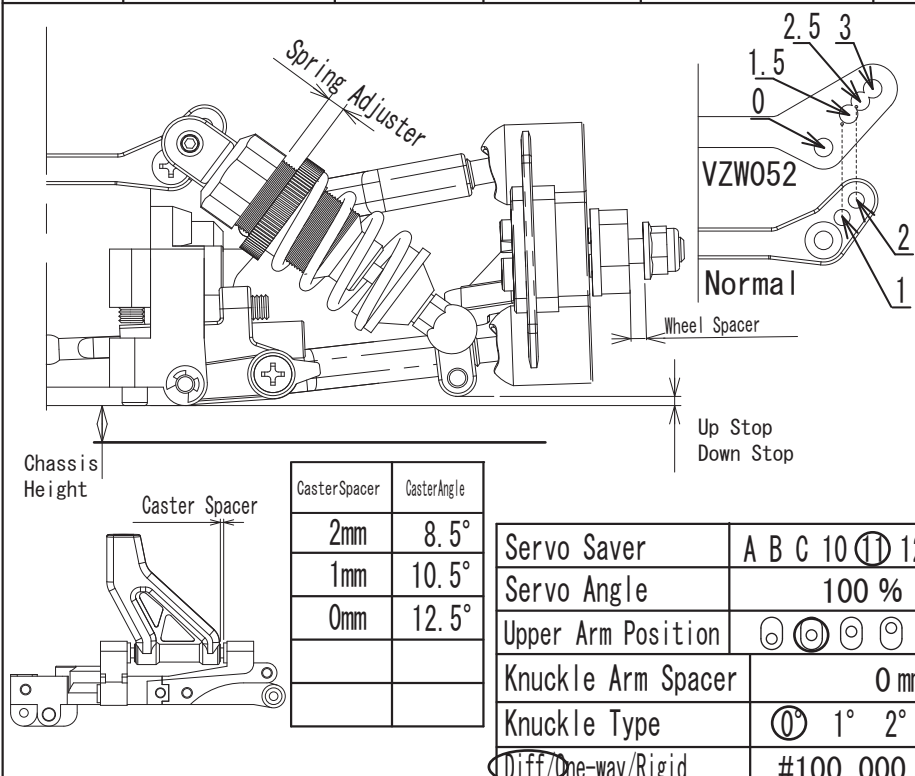

Shock Oil	300 350 400 450 <u>500</u> 550 600 700 800
Diaphragm	(N)
Shock Piston	(N)
Spring	KYOSHO BLUE
Spring Adjuster	mm
Shock Position	0 1 1.5 2 <u>2.5</u> 3
Caster Angle	2 mm
Camber Angle	L 0 0.5 <u>1</u> 1.5 2 2.5 3 R 0 0.5 <u>1</u> 1.5 2 2.5 3
Toe Angle	-1°
Front Width	199 mm
Up Stop	mm
Down Stop	-1 mm
Antiroll Bar	SOFT HARD <input checked="" type="radio"/> <input type="radio"/> <input type="radio"/> <input type="radio"/> <input type="radio"/>
Tire	Active Hobby
Wheel Offset	0 <u>1</u> 2
Tire Diameter	φ62 mm
Chassis Height	7 mm
Wheel Spacer	1 mm

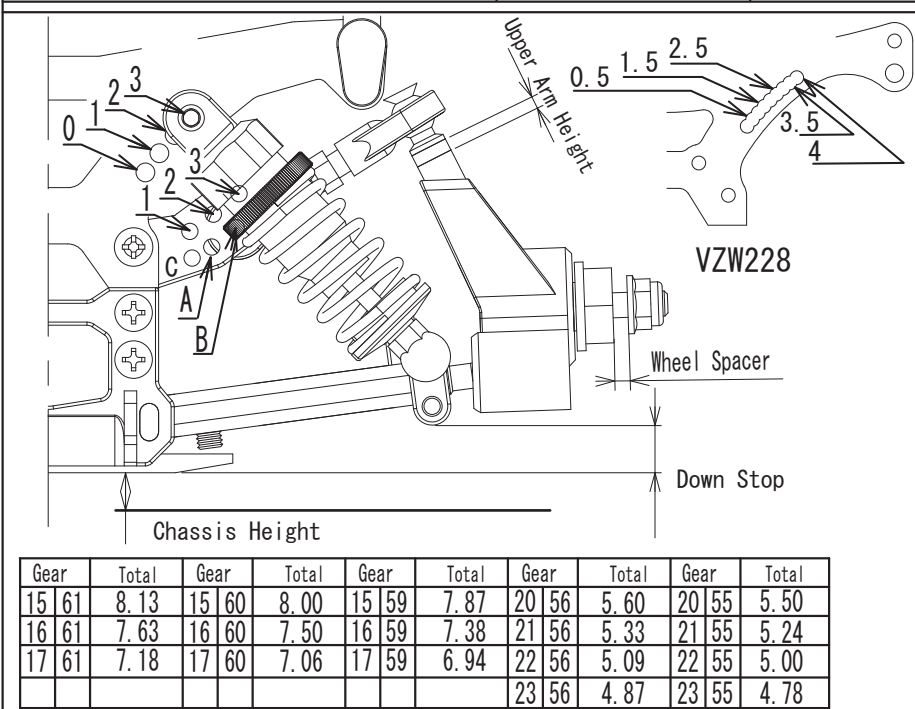

Shock Oil	300 350 400 450 <u>500</u> 550 600 700 800
Diaphragm	(N)
Shock Piston	(N)
Spring	KYOSHO BLUE
Spring Adjuster	mm
Shock Position	0/0.5/1/1.5/2/2.5/3/3.5/4
Wheel Spacer	<u>0mm</u> 1mm/1.5mm/2mm/2.5mm
Upper Arm Height	2mm 1 / 2 / 3 / A / B / <u>C</u>
Camber Angle	L 0 0.5 1 1.5 <u>2</u> 2.5 3 3.5 4 R 0 0.5 1 1.5 <u>2</u> 2.5 3 3.5 4
Toe Angle	3°
Rear Width	199 mm
Down Stop	3 mm
Antiroll Bar	1.8/ <u>2.0</u> /2.3/ ADJ <input type="radio"/>
Tire	Active Hobby
Wheel Offset	0 <u>1</u> 2
Tire Diameter	φ64 mm
Chassis Height	7.5 mm
Lower Arm Position	<input type="radio"/> <input type="radio"/> <input type="radio"/> <input type="radio"/>
Body	BLIZ ALTIS
Body Position	mm
Wing Height	mm
Wing Angle	°

Clutch Type	<u>VZW229</u> SIRIO	Pinion Gear	15 16 <u>17</u> / 20 21 <u>22</u> 23
Clutch Shoe	<u>Grey</u> / SIRIO BLUE	Spur Gear	59 60 <u>61</u> / <u>55</u> 56
Clutch Weight	(N)	Drive Ratio	0mm Difference (24T Pully 387Belt) <u>2mm Difference (23T Pully 384Belt)</u>
Clutch Spring	FM432	Brake	%
Clearance	0.4 mm	Rear Diff	#20,000
Adjust Nut	0.9 mm		

Memo