

Name	t.mizowaki	Temp	°C	Engine	OS T1201	Muffler	OS
Date	2014.10	Humidity	%	Head Clearance	mm	Fuel Type	cosmo
Track	BOSS	Traction	%	Plug No.		Radio	Futaba

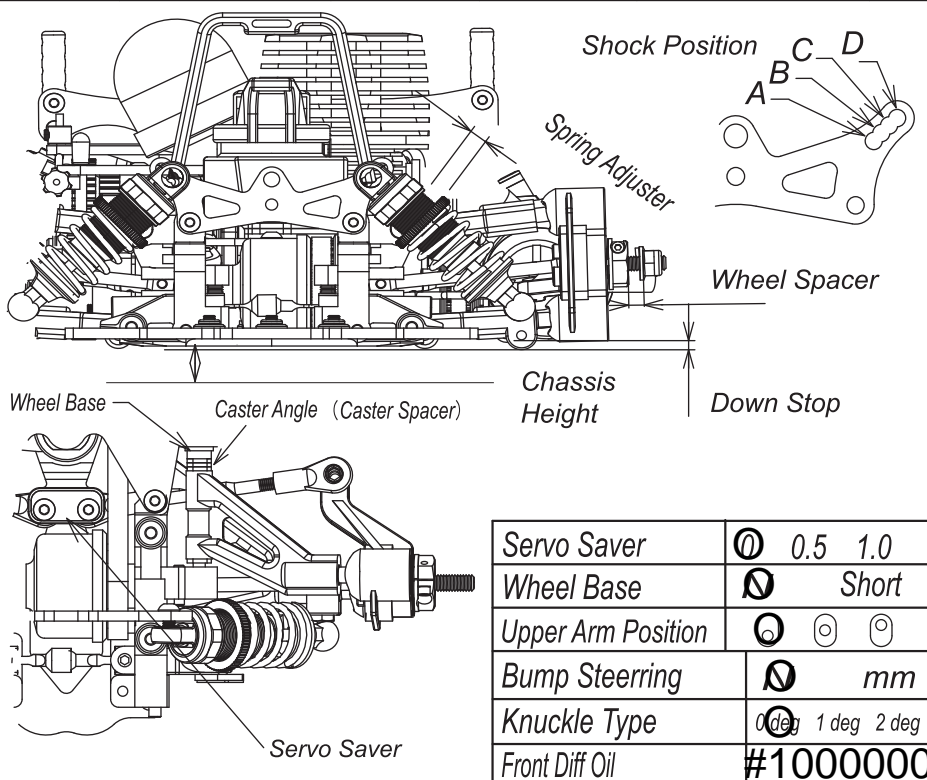

Shock Oil	300 350 400 450 <input checked="" type="radio"/> 550 600 700 800
Diaphragm	<input checked="" type="radio"/>
Shock Piston	<input checked="" type="radio"/>
Spring	kyosho light blue
Spring Adjuster	about mm
Shock Position	A <input checked="" type="radio"/> B C D
Caster Angle (Spacer)	2 mm
Camber Angle	L 0 0.5 <input checked="" type="radio"/> 1 1.5 2 2.5 3 R 0 0.5 <input checked="" type="radio"/> 1 1.5 2 2.5 3
Toe Angle	-1 deg
Front Width	198 mm
Down Stop	-1 mm
Wheel Spacer	0 mm
Antiroll Bar	VZ084SS Super Soft <input checked="" type="radio"/> / Sway (φ) mm VZ084S Soft
Tire	BOSSリサイクル / S.S.R deg
Wheel Offset Type	mm
Tire Diameter	61 mm
Chassis Height	4.5 mm
Used Optional parts	

Servo Saver	<input checked="" type="radio"/> 0.5 1.0
Wheel Base	<input checked="" type="radio"/> Short
Upper Arm Position	<input checked="" type="radio"/> <input type="radio"/> <input type="radio"/>
Bump Steering	<input checked="" type="radio"/> mm
Knuckle Type	<input checked="" type="radio"/> 0 deg 1 deg 2 deg
Front Diff Oil	#1000000

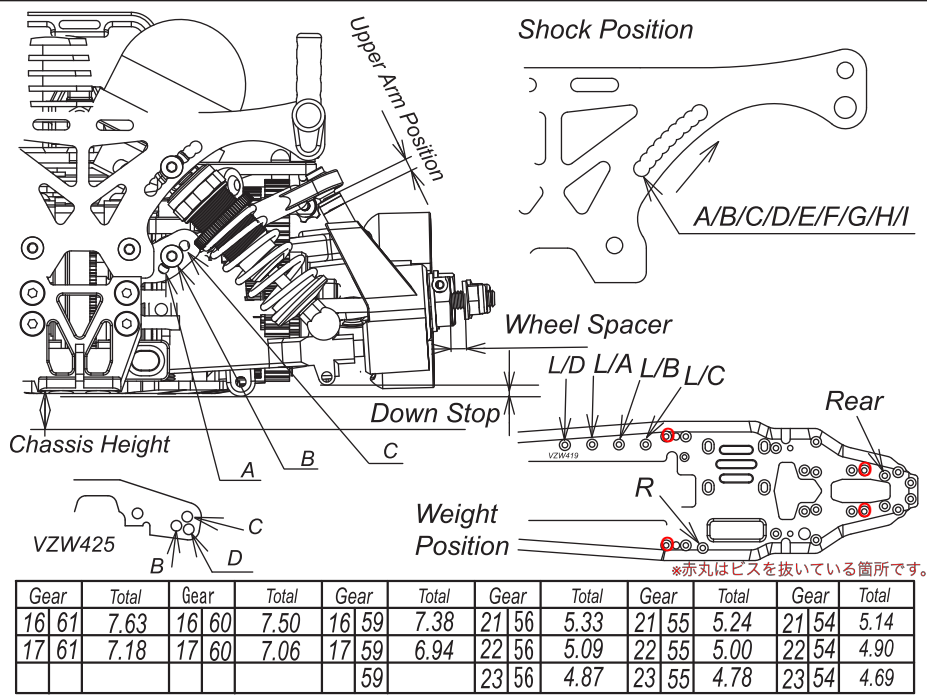

Shock Oil	300 350 400 450 <input checked="" type="radio"/> 550 600 700 800
Diaphragm	<input checked="" type="radio"/>
Shock Piston	<input checked="" type="radio"/>
Spring	kyosho red
Spring Adjuster	about mm
Shock Position	A/B/C/D/E/F/G/H/I
Wheel Spacer	0 mm
Upper Arm Position	1 mm A/B/C/D
Camber Angle	L 0 0.5 1 1.5 2 2.5 <input checked="" type="radio"/> 3 3.5 4 R 0 0.5 1 1.5 2 2.5 <input checked="" type="radio"/> 3 3.5 4
Toe Angle	3 deg
Rear Width	199 mm
Down Stop	1 mm
Antiroll Bar	N2.2mm
Tire	BOSSリサイクル / R38 deg
Wheel Offset Type	mm
Tire Diameter	63 mm
Chassis Height	5 mm

Clutch Type	<input checked="" type="radio"/> VZW229	Pinion Gear	(15) 16 <input checked="" type="radio"/> 17 (20) 21 <input checked="" type="radio"/> 22 23
Clutch Shoe	N / VZW229-03 Yellow	Spur Gear	59 60 <input checked="" type="radio"/> 61 / 54 <input checked="" type="radio"/> 55 56
Clutch Weight	<input checked="" type="radio"/> Other ()	Drive Ratio	0mm Difference (24T Pully 387Belt)
Clutch Spring	N (□1.7) / VZW44 (□1.8)		2.5mm Difference (23T Pully 384Belt)
Clearance	0.8 mm	Rear Diff Oil	#50000
Adjust Nut	1.6 mm	Main Chassis	N (VZ437) / VZW419

Memo オプションパーツ:SPブレキパッド(MP777/WC) IFW330、アルミサポセイバー (R4) VZW404、カーボンフロントバンパープレートセット (R4) VZW411、ユニバーサルスイングシャフトセット (R4/リヤ用/2pcs) VZW413、アルミブレーキレバー (R4) VZW421、*Fのみドッグボーン使用
アルミフロントアッパーパルクセット (L/R/R4) VZW423、アルミリヤパルクアッパーセット (L R/R4) VZW425 F:半塗り、R:全塗り