

Tire	Remodeling	Width Cut	
Tire	Wheel	Inner	
Front	Hole Shot M3	Wide/Normal	Inclusion Cut
Rear	Hole Shot M3	Wide/Normal	Inclusion

Wide = Kit Including

Name: T.SANPEI Date: 00/10/22 Truck: YATABE

Shock	Piston	Oil	Spring	Type
Front	2-C	#350	#70	P (N)
Rear	2-B	#400	#70	P (N)

P = Pressure Type, N = Non-Pressure Type

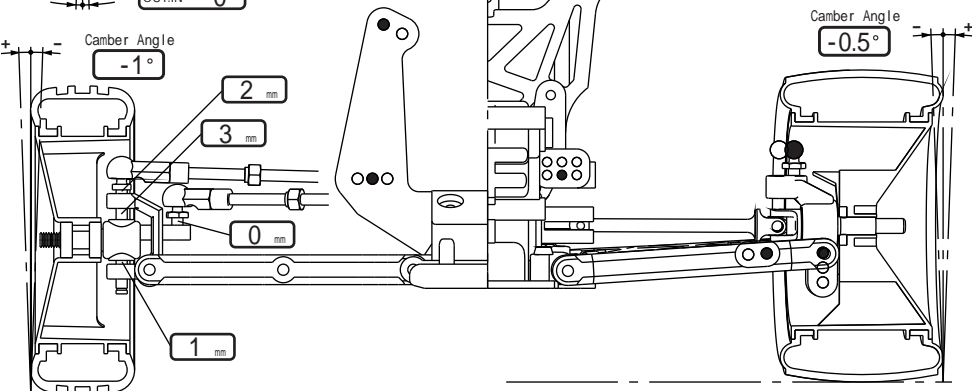
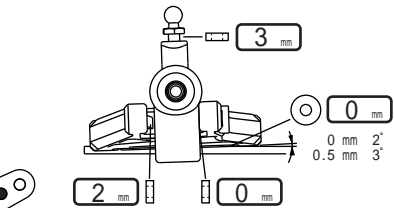
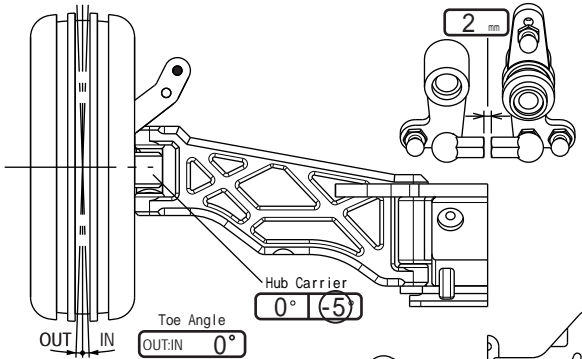
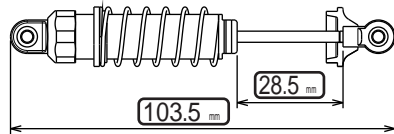
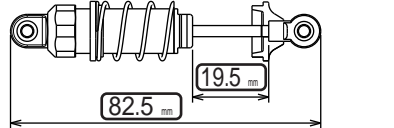
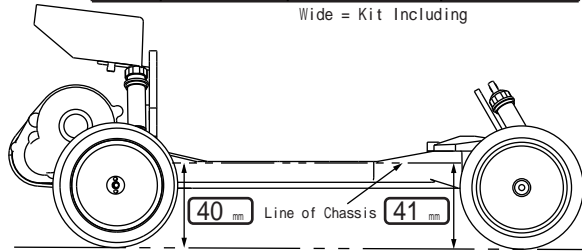

Gear Ratio	Motor LUNA ASMO 11T					Spur Gear 82T					Pinion Gear 20T																															
	16	17	18	19	20	21	22	23	24	25	26	27	28	29	30																											
2.50 (22:55)	84	13.13	12.35	11.67	11.05	10.50	10.00	9.55	9.13	8.75	83	12.97	12.21	11.53	10.92	10.38	9.88	9.43	9.02	8.65	8.30	82	12.81	12.06	11.39	10.79	10.25	9.76	9.32	8.91	8.54	8.20	81	11.91	11.25	10.66	10.13	9.64	9.20	8.80	8.44	8.10

No.	Color
#50	Black
#55	Orange
#60	Orange Yellow
#65	Yellow
#70	Silver
#75	Light Green
#80	Green

Shock Piston  
 2-B 2-C 2-D  
 3-A 3-B  
 Own composition (2-1.3)

Tire	Remodeling	Width Cut	
Tire	Wheel	Inner	
Front	Hole Shot M3	Wide/Normal	Inclusion Cut
Rear	Hole Shot M3	Wide/Normal	Inclusion

Wide = Kit Including

Name: S.KIMURA Date: 00/10/22 Truck: YATABE

Shock	Piston	Oil	Spring	Type
Front	2-C	#400	#70	P (N)
Rear	2-B	#400	#70	P (N)

P = Pressure Type, N = Non-Pressure Type

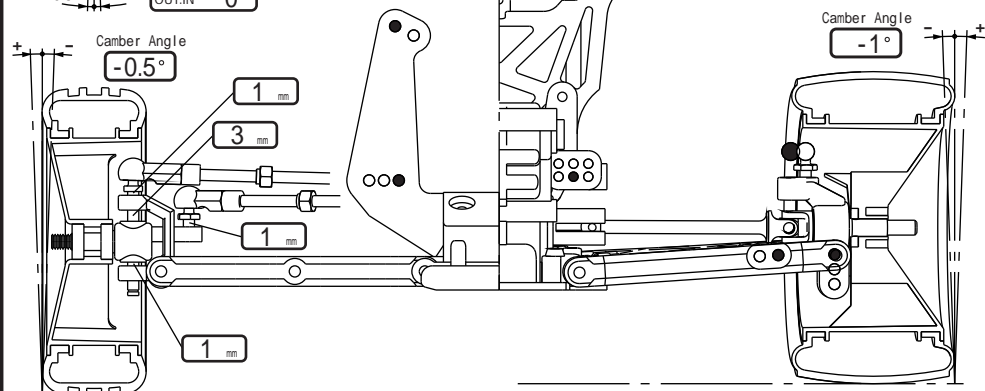
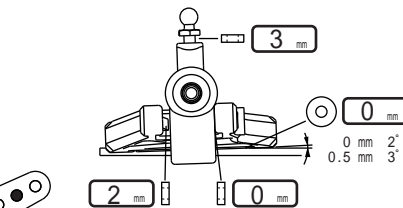
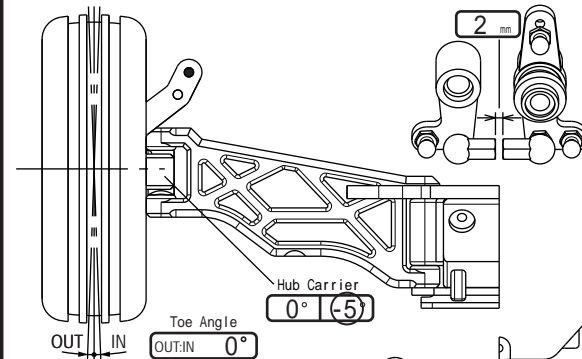
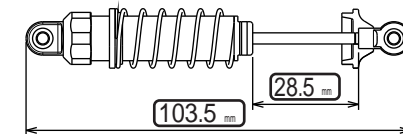
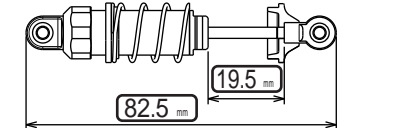
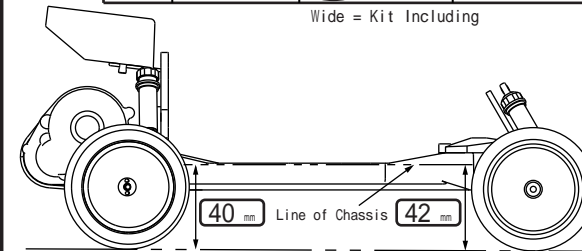

Gear Ratio	Motor ATLAS BULLEE 10T					Spur Gear 82T					Pinion Gear 20T																															
	16	17	18	19	20	21	22	23	24	25	26	27	28	29	30																											
2.50 (22:55)	84	13.13	12.35	11.67	11.05	10.50	10.00	9.55	9.13	8.75	83	12.97	12.21	11.53	10.92	10.38	9.88	9.43	9.02	8.65	8.30	82	12.81	12.06	11.39	10.79	10.25	9.76	9.32	8.91	8.54	8.20	81	11.91	11.25	10.66	10.13	9.64	9.20	8.80	8.44	8.10

No.	Color
#50	Black
#55	Orange
#60	Orange Yellow
#65	Yellow
#70	Silver
#75	Light Green
#80	Green

Shock Piston  
 2-B 2-C 2-D  
 3-A 3-B  
 Own composition (2-1.3)