

Name
宮崎和弘

Date
2009. 10. 18

Truck / City
中京大会 (特設)

Event
京商トロフィー

Front Suspension

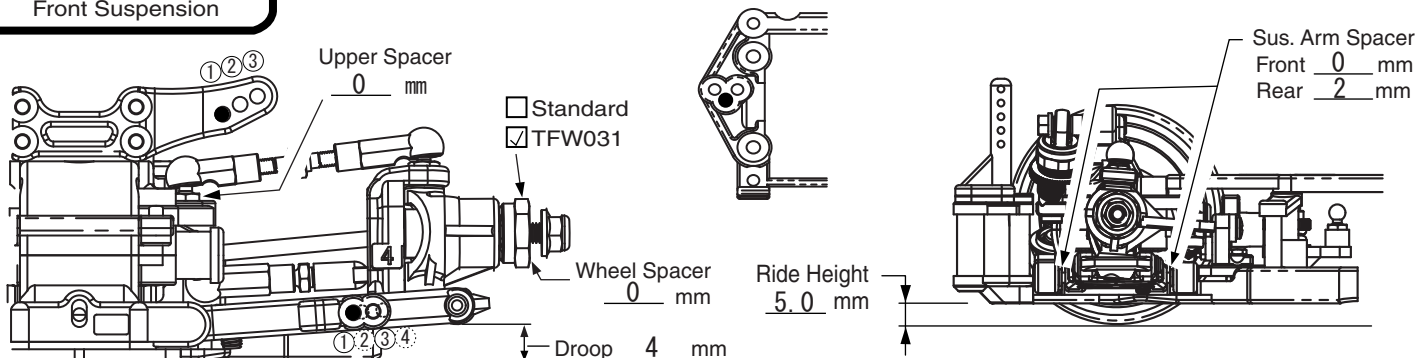

Sus. Holder Spacer

- Front Rear

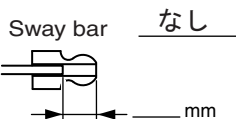

Toe Angle 0°

Camber Angle 1.5°

Front Diff.

- Spool
 Oneway
 Diff.

Rear Suspension

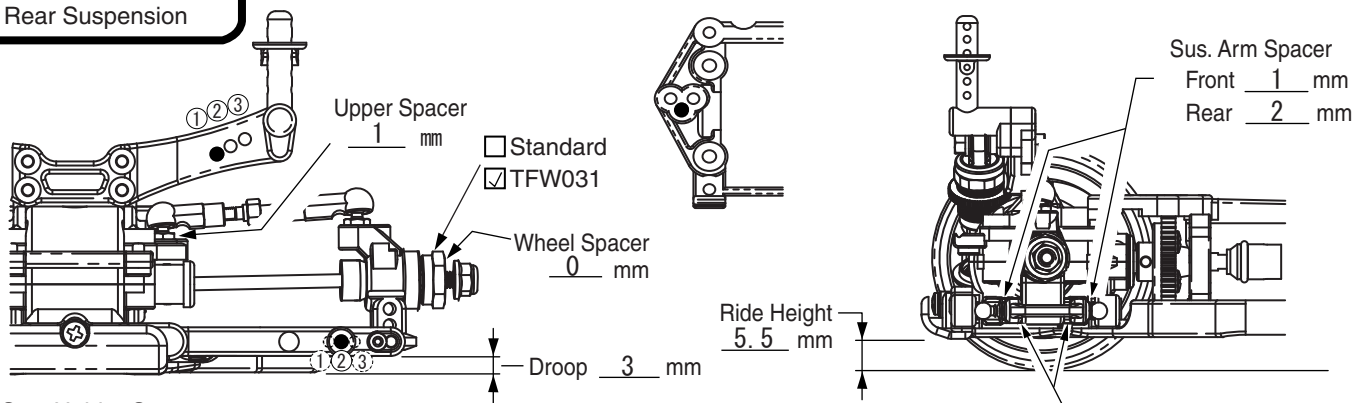

Sus. Holder Spacer

- Front Rear

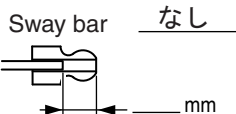

Toe Angle ____°

Camber Angle 1.5°

Hub Carrier Spacer
Front 2 mm
Rear 0 mm

Shock

	Front	Rear
Shock Piston	W5194-01 2C	W5194-01 2C
Shock Oil	# 500	# 500
Shock Spring	kit標準	kit標準
Diaphragm	標準	標準
Pressure Form	標準	標準
Shock Length	60 mm	63 mm

Standard W5189

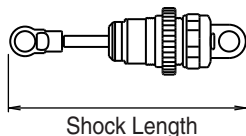

Weight Placement

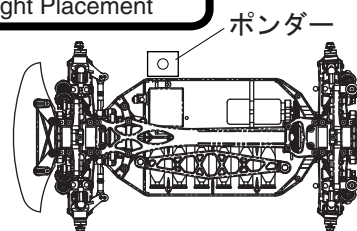

Tire

Tire	Comments
KCスリック M	-----
Inserts 96250M 京商マ7M	-----
Wheel VZH001 京商6本スポーク	-----
Traction Compound 1st: マイティ 2nd:	-----

Others

Motor G20	2nd Gear Ratio : 2.5
Pinion/Spur 36 / 68	Gear Ratio 4.73
Battery Orion3300	ESC KO VFS-1
Body SC430	Wing 標準

Truck Condition

- Smooth Asphalt
 Bumpy Concrete
 Low Truction Carpet
 Med. Truction Indoor
 Higt Truction Outdoor

Comment :

リヤサスホルダーTF131使用。(F:outC, RF:inB, RR:outF)