

Name Shinnosuke Adachi

Date 2006. 8. 18

Truck / City 谷田部アリーナ

Event _____

Front Suspension

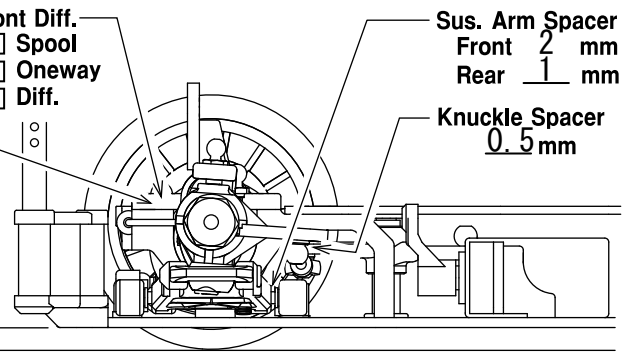
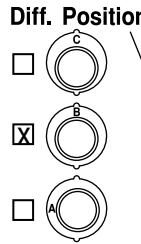
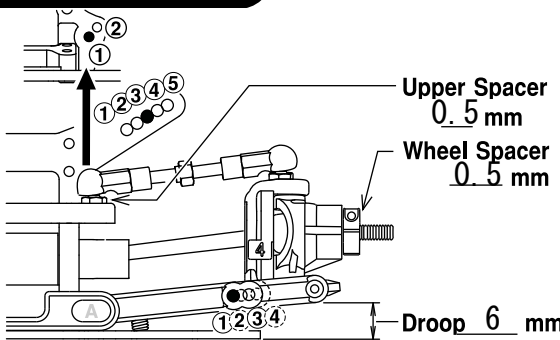

Sus. Holder Bush

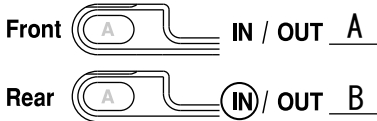

Sus. Holder Spacer

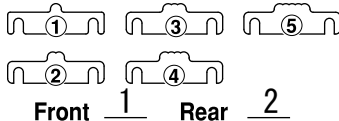

Sway bar 1.2 mm

Toe Angle 0 °

0 mm

Camber Angle 1.5 °

Rear Suspension

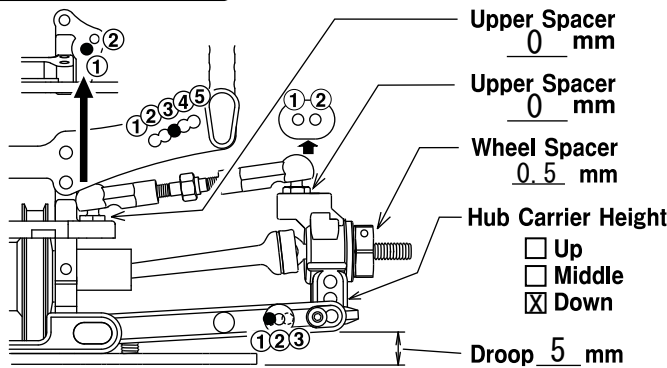

Diff. Position

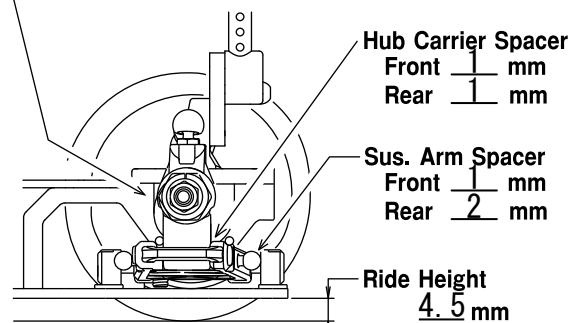

Sus. Holder Bush

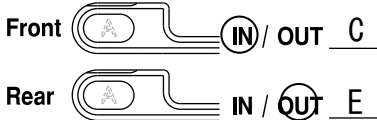

Sus. Holder Spacer

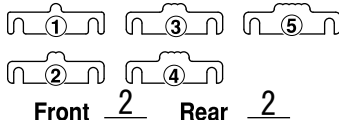

Sway bar 1.0 mm

Hub Carrier

- 0mm offset (SP107H)
 1.2mm offset (TF009)

3 mm

Camber Angle 1.5 °

Shock

	Front	Rear
Shock Piston	<u>1.1-3</u>	<u>1.1-3</u>
Shock Oil	<u>#400</u>	<u>#300</u>
Shock Spring	<u>イエロー</u>	<u>レッド</u>
Diaphragm	<u>std</u>	<u>std</u>
Pressure Form	<u>Form</u>	<u>Form</u>
Shock Length	<u>61 mm</u>	<u>62 mm</u>

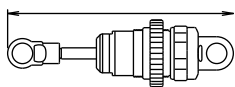

Steering Wiper

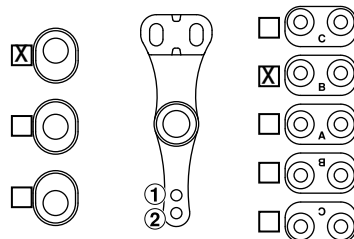

Weight Placement

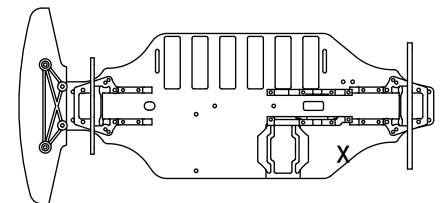

Tire

Tire	Comments
<u>SOREX36R</u>	-----
Inserts <u>039M</u>	-----
Wheel <u>YOKOMO プレジジョン</u>	-----
Traction Compound	-----
<u>1st: コバトーン 2nd: FX II</u>	-----

Others

Motor <u>Gスタイル G</u>	2nd Gear Ratio : <u>1.83</u>
Pinion/Spur <u>35 / 102</u>	Gear Ratio <u>5.33</u>
Battery <u>SMC 1B4200</u>	ESC <u>K0</u>
Body <u>ライドマークIII 軽量 Wing</u>	<u>ごくらく3ストレート</u>

Truck Condition

- Smooth Asphalt
 Bumpy Concrete
 Low Truction Carpet
 Med. Truction Indoor
 Higt Truction Outdoor

Comment :

センターワンウェイを使用。