

Name Shinnosuke Adachi

Date 2006. 8. 6

Truck / City K-Studio

Event サーキット破り

Front Suspension

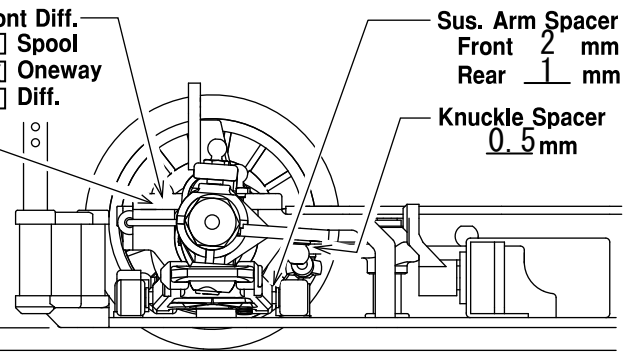
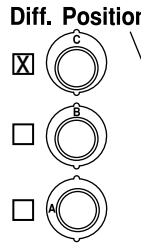
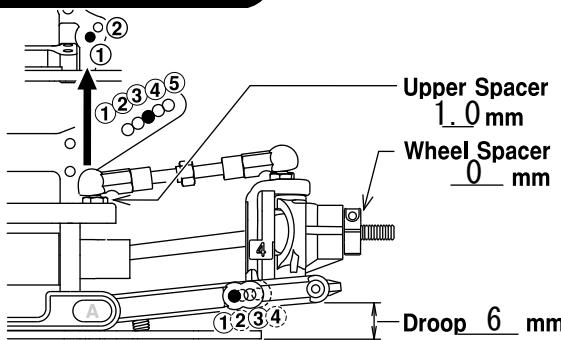

Sus. Holder Bush

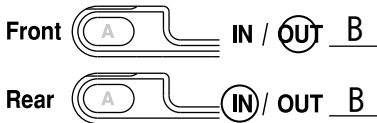

Sus. Holder Spacer

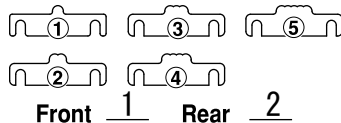

Sway bar 1.0 mm

Toe Angle 0 °

0 mm

Camber Angle 1.5 °

Rear Suspension

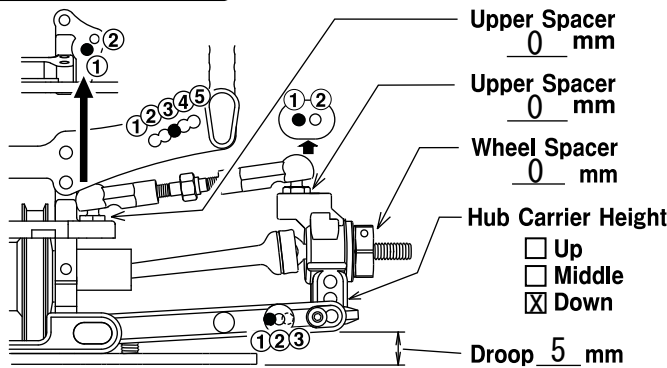

Diff. Position

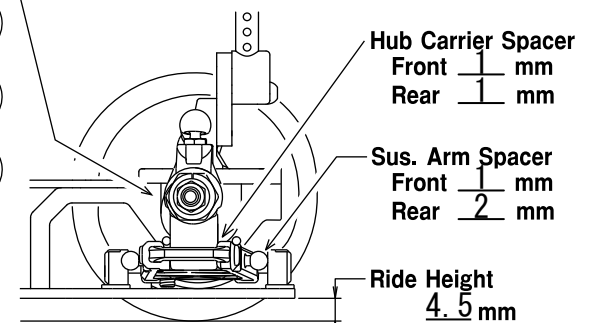
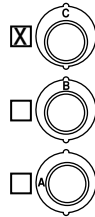

Sus. Holder Bush

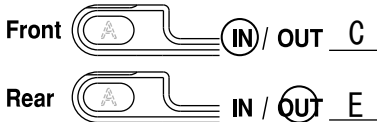

Sus. Holder Spacer

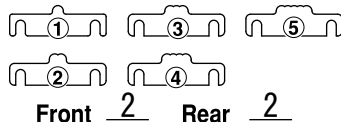

Sway bar 1.0 mm

Hub Carrier

- 0mm offset (SP107H)
 1.2mm offset (TF009)

4 mm

Camber Angle 1.5 °

Shock

	Front	Rear
Shock Piston	<u>1.1-3</u>	<u>1.1-3</u>
Shock Oil	<u>#400</u>	<u>#300</u>
Shock Spring	<u>イエロー</u>	<u>レッド</u>
Diaphragm	<u>std</u>	<u>std</u>
Pressure Form	<u>X0リング</u>	<u>X0リング</u>
Shock Length	<u>62</u> mm	<u>62</u> mm

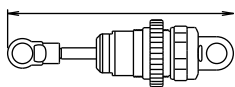

Steering Wiper

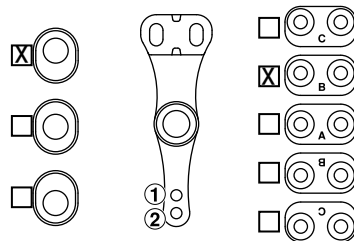

Weight Placement

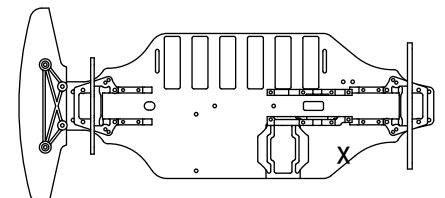

Tire

	Comments
Tire	<u>SOREX36Ror40R</u>
Inserts	<u>AH ブラック</u>
Wheel	<u>KYOSHO デイツシュ</u>
Traction Compound	<u>1st:ネバトーン 2nd:FX II</u>

Others

Motor Gスタイル 23T 2nd Gear Ratio : 1.83
Pinion/Spur 33 / 102 Gear Ratio 5.65
Battery SMC IB4200 ESC KO-VFS1Camp2
Body ライドマークIII 軽量Wing ごくらく3ストレート

Truck Condition

- Smooth Asphalt
 Bumpy Concrete
 Low Traction Carpet
 Med. Traction Indoor
 High Traction Outdoor

Comment :

OPセンターワンウェイを使用。