

Name
滝沢 豊

Date
2006. 8. 16

Truck / CITY
谷田部アリーナ

Event

Front Suspension

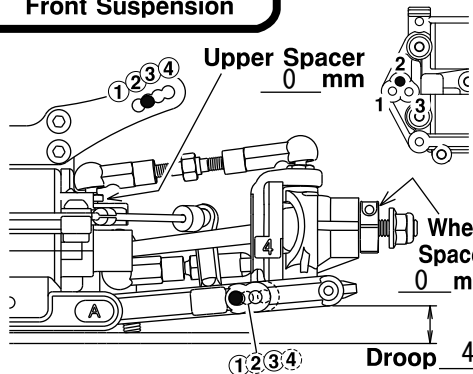

Shock Piston ノーマル
Shock Oil # 450
Shock Spring ブルー
Diaphragm ノーマル
Pressure Form ノーマル

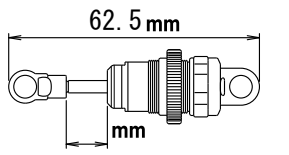

Camber Angle -1°
Toe Angle -1°
Sway bar 無しmm

Front Diff.
 Spool
 Oneway
 Diff.

Battery Placement
 Forward
 Rear
Post High Spacer
 Up
 Low

Sus. Holder Spacer



Sus. Holder Bush

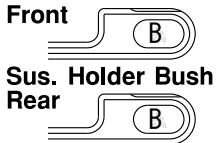

Ride Height 4.5 mm

Sus. Arm Spacer Front 1 mm Rear 2 mm

Crank Spacer ___ mm
Bump Steer Spacer ___ mm

Rear Suspension

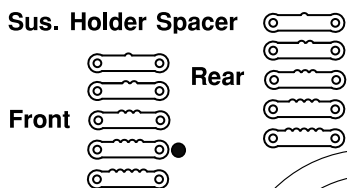

Shock Piston ノーマル
Shock Oil # 450
Shock Spring レッド
Diaphragm ノーマル
Pressure Form ノーマル

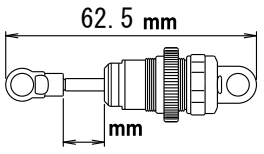

Camber Angle -1°
Toe Angle 3°
Sway bar 無し

Upper Spacer 0 mm

Upper Spacer 0.5 mm

Wheel Spacer 0.5 mm

Hub Carrier Height

Up

Middle

Down

Droop 3.3 mm

Sus. Arm Spacer Front 1 mm Rear 2 mm

Hub Carrier Spacer Front 2 mm Rear 0 mm

Sus. Holder Bush Front D

Sus. Holder Bush Rear D

Tire

Tire SOREX36R
Inserts ゼノンオレンジ
Wheel ゼノン
Traction Compound 1st: Xギアコバトーン 2nd: パラゴン FX11

Comments

Others

Motor イリュージョンLT 2nd Gear Ratio : 2.5
Pinion/Spur 42 / 90 Gear Ratio 5.36
Battery SMC IB4200 ESC 7ギア MC800C Ver. 2
Body マツダ 6 Wing ゼノンタイプB

Truck Condition

Smooth Asphalt
 Bumpy Concrete
 Low Traction Carpet
 Med. Traction Indoor
 High Traction Outdoor

Spring Rate

#30	Red	W5189-30
#32	Yellow	W5189-32
#34	Blue	W5189-34

Diaphragm



Toe Angle

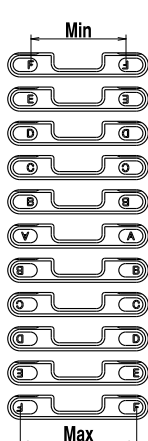

Weight Placement

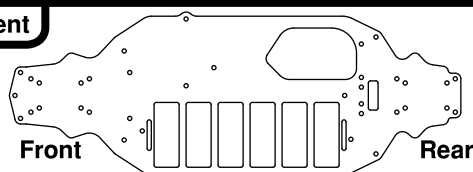

Shock Piston

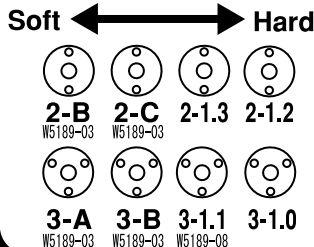

Sway Bar

1.0	Nickel
1.1	Gold
1.2	Silver
1.3	Copper
1.4	Black
1.5	Golden
1.6	Chromium

		in					Out					
		FF	EE	DD	CC	BB	AA	BB	CC	DD	EE	FF
In	FF	0.0	0.5	1.0	1.5	2.0	2.5	3.0	3.5	4.0	5.0	5.5
	EE	-0.5	0.0	0.5	1.0	1.5	2.0	2.5	3.0	3.5	4.0	5.0
	DD	-1.0	-0.5	0.0	0.5	1.0	1.5	2.0	2.5	3.0	3.5	4.0
	CC	-1.5	-1.0	-0.5	0.0	0.5	1.0	1.5	2.0	2.5	3.0	3.5
	BB	-2.0	-1.5	-1.0	-0.5	0.0	0.5	1.0	1.5	2.0	2.5	3.0
Out	AA	-2.5	-2.0	-1.5	-1.0	-0.5	0.0	0.5	1.0	1.5	2.0	2.5
	BB	-3.0	-2.5	-2.0	-1.5	-1.0	-0.5	0.0	0.5	1.0	1.5	2.0
	CC	-3.5	-3.0	-2.5	-2.0	-1.5	-1.0	-0.5	0.0	0.5	1.0	1.5
	DD	-4.0	-3.5	-3.0	-2.5	-2.0	-1.5	-1.0	-0.5	0.0	0.5	1.0
	EE	-5.0	-4.0	-3.5	-3.0	-2.5	-2.0	-1.5	-1.0	-0.5	0.0	0.5
FF	-5.5	-5.0	-4.0	-3.5	-3.0	-2.5	-2.0	-1.5	-1.0	-0.5	0.0	