

Name
足立 伸之介

Date
2006/03/26

Truck / CITY
矢田部アリーナ

Event
スーパーストック選手権

Front Suspension

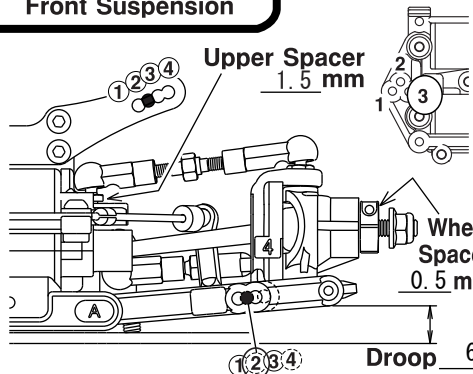

Shock Piston 3 - 1.1
Shock Oil # 400
Shock Spring Blue
Diaphragm W5189-05
Pressure Form None

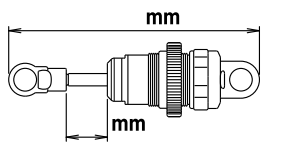

Camber Angle 1.5°
Toe Angle 0°
Sway bar 1.4mm

Front Diff.
 Spool
 Oneway
 Diff.

Battery Placement
 Forward
 Rear
Post High Spacer
 Up
 Low

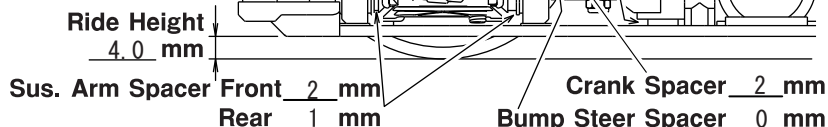
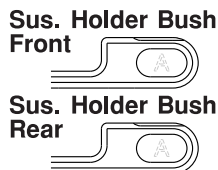
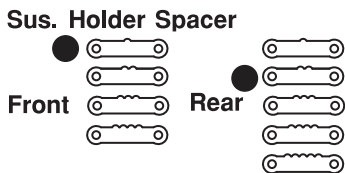

Rear Suspension

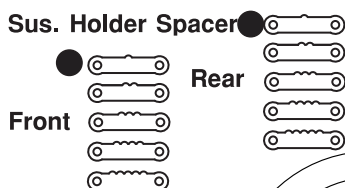

Shock Piston 3 - 1.1
Shock Oil # 350
Shock Spring Red
Diaphragm W5189-05
Pressure Form None

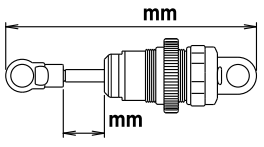

Camber Angle 1.5°
Toe Angle 3°
Sway bar 1.2mm

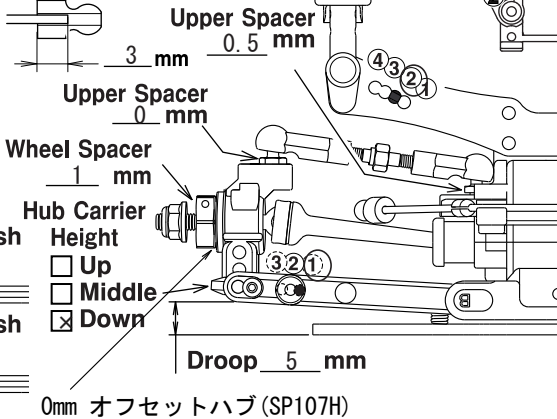

Tire

Tire SOREX 32R

Inserts AH ブラック

Wheel エアロディッシュ・ハード

Traction Compound 1st: コバトーン 2nd: FX 11

Comments

Others

Motor G-STYLE 2nd Gear Ratio : 2.5

Pinion/Spur 42 / 88 Gear Ratio 5.23

Battery G-STYLE ESC VFS-1Comp

Body ライドマークIII 軽量 Wing ごくらく3ストレート

Truck Condition

Smooth Asphalt

Bumpy Concrete

Low Traction Carpet

Med. Traction Indoor

High Traction Outdoor

Spring Rate

#30	Red	W5189-30
#32	Yellow	W5189-32
#34	Blue	W5189-34

Diaphragm



Toe Angle

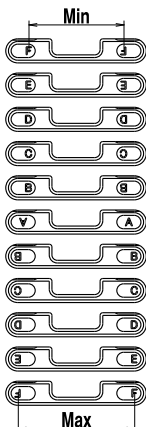

Weight Placement

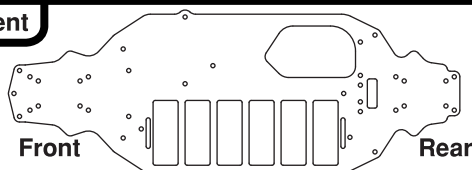

Shock Piston

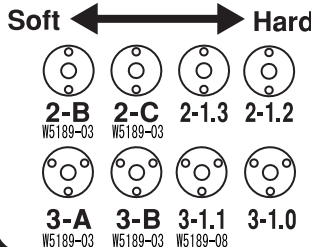

Sway Bar

1.0	Nickel
1.1	Gold
1.2	Silver
1.3	Copper
1.4	Black
1.5	Golden
1.6	Chromium

		in					Out					
		FF	EE	DD	CC	BB	AA	BB	CC	DD	EE	FF
In	FF	0.0	0.5	1.0	1.5	2.0	2.5	3.0	3.5	4.0	5.0	5.5
	EE	-0.5	0.0	0.5	1.0	1.5	2.0	2.5	3.0	3.5	4.0	5.0
	DD	-1.0	-0.5	0.0	0.5	1.0	1.5	2.0	2.5	3.0	3.5	4.0
	CC	-1.5	-1.0	-0.5	0.0	0.5	1.0	1.5	2.0	2.5	3.0	3.5
	BB	-2.0	-1.5	-1.0	-0.5	0.0	0.5	1.0	1.5	2.0	2.5	3.0
Out	AA	-2.5	-2.0	-1.5	-1.0	-0.5	0.0	0.5	1.0	1.5	2.0	2.5
	BB	-3.0	-2.5	-2.0	-1.5	-1.0	-0.5	0.0	0.5	1.0	1.5	2.0
	CC	-3.5	-3.0	-2.5	-2.0	-1.5	-1.0	-0.5	0.0	0.5	1.0	1.5
	DD	-4.0	-3.5	-3.0	-2.5	-2.0	-1.5	-1.0	-0.5	0.0	0.5	1.0
	EE	-5.0	-4.0	-3.5	-3.0	-2.5	-2.0	-1.5	-1.0	-0.5	0.0	0.5
FF	-5.5	-5.0	-4.0	-3.5	-3.0	-2.5	-2.0	-1.5	-1.0	-0.5	0.0	