

FW-05S

SETTING DATA SHEET Ver1.00

NAME	Team Moritadenki	TEMP	10 °C	ENGINE	GS15	MUFFLER	VSW011	MANIFOLD	FW-04 Cream-colored
DATA	2004. 1. 11	HUMIDITY	%	HEAD CLEARANCE	Normal	FUEL TYPE	BP 30%		
TRACK	京商サーキット	TRACTION	%	PLUG No.	Enya No. 5	RADIO	SANWA M8		

FRONT

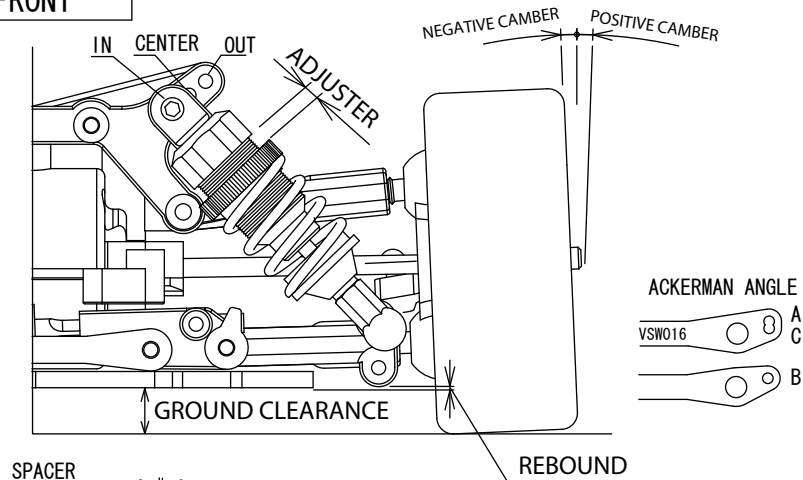

CASTER	ANGLE
2mm	10°
1mm	8°
0mm	6°

DIFF. / ONEWAY	
DIFF OIL	# 30,000
ACKERMAN ANGLE	A B C
ST D/R	120 %

SHOCK OIL	300 350 400 450 500 550 600 700
SHOCK PISTON	1.2φ 1Hole
SPRING	Yellow 92491
SPRING ADJUSTER	3.5 mm
SHOCK POS	U IN CENTER OUT L U L
CASTER ANGLE	2 mm
CAMBER ANGLE	OG 1G 0 0.5 1.0 1.5 2.0
TOE ANGLE	-0.5 mm
FRONT WIDTH	198 mm
REBOUND STOP	0 mm
STABILIZER BAR	
TIRE TYPE	V30
TIRE SIZE	Kyosho No. 92013
WHEEL	92012
GROUND CLEARANCE	6 mm
RING GEAR	39T 40T

REAR

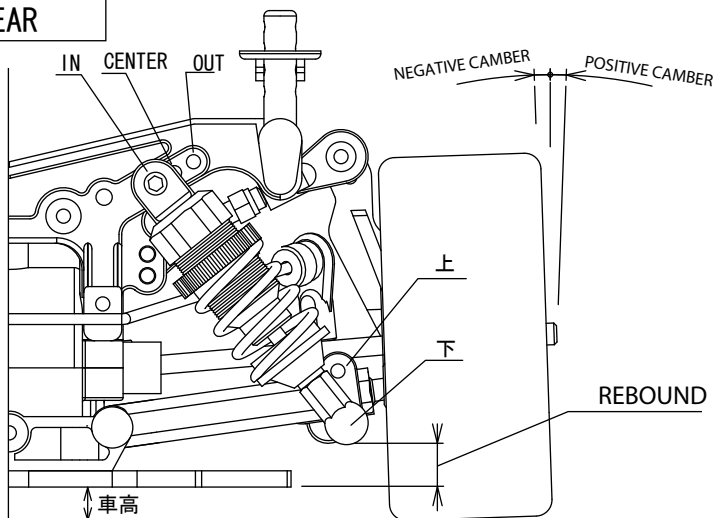

RING GEAR 39T					
GEAR	TOTAL	GEAR	TOTAL		
20	50	7.50	25	45	5.40
20	51	7.65	25	46	5.52
21	50	7.14	26	45	5.19
21	51	7.28	26	46	5.30
22	50	6.81	27	45	5.00
22	51	6.95	27	46	5.11

RING GEAR 40T					
GEAR	TOTAL	GEAR	TOTAL		
20	50	7.69	25	45	5.54
20	51	7.85	25	46	5.66
21	50	7.33	26	45	5.33
21	51	7.47	26	46	5.44
22	50	6.99	27	45	5.13
22	51	7.13	27	46	5.24

SHOCK OIL	300 350 400 450 500 550 600 700
SHOCK PISTON	N 1.2φ 1Hole
SPRING	Yellow 92491
SPRING ADJUSTER	1.5 mm
SHOCK POS	IN CENTER OUT
SHOCK POS	U / L
UPPER ARM POS	IN (U/L) - OUT (U/L)
CAMBER ANGLE	OG 1G 0 0.5 1.0 1.5 2.0 2.5 3.0
TOE ANGLE	+1.5
REAR WIDTH	198 mm
REBOUND STOP	3 mm
STABILIZER BAR	SILVER BLACK GOLD
REAR SUS. HOLDER	H L
DIFF OIL	# 5,000
TIRE TYPE	V30
TIRE INNER	Kyosho No. 92013
WHEEL	92012
GROUND CLEARANCE	6 mm
BODY	2003 NSX
GEAR	20 21 22 / 25 26 27
GEAR	50 51 / 45 46
RING GEAR	39T 40T
CLUCH SHOE	VESPEL
CLUCH SPRING	HARD (BLUE)

memo.