

Name	t.mizowaki	Temp	°C	Engine	OS 12TG	Muffler	OS T-1070
Date	2016.3.6	Humidity	%	Head Clearance	mm	Fuel Type	NASA
Track	R246	Traction	70 %	Plug No.		Radio	Futaba

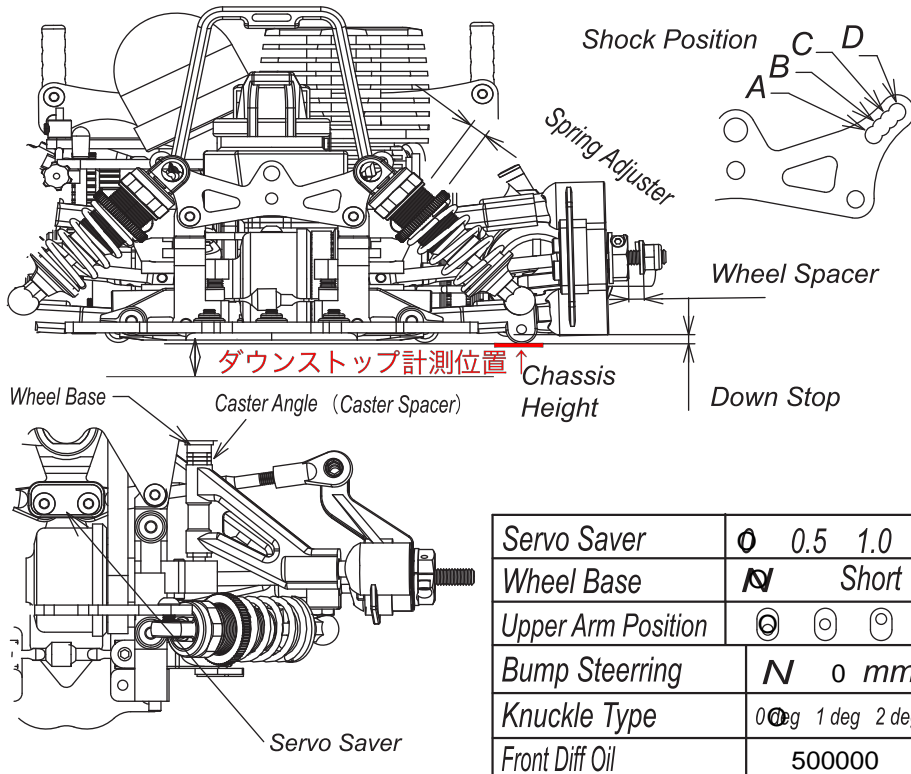

Servo Saver	0 0.5 1.0
Wheel Base	Short
Upper Arm Position	⊙ ⊙ ⊙
Bump Steering	N 0 mm
Knuckle Type	0 deg 1 deg 2 deg
Front Diff Oil	50000

Shock Oil	300 350 400 450 500 550 600 700 800
Diaphragm	N
Shock Piston	N
Spring	TF027S-03
Spring Adjuster	mm
Shock Position	A B C D
Caster Angle (Spacer)	2 mm
Camber Angle	L 0 1 1.5 2 2.5 3 R 0 1 1.5 2 2.5 3
Toe Angle	-1 deg
Front Width	198 mm
Down Stop	-3 mm
Wheel Spacer	0 mm
Antiroll Bar	VZ084SS Super Soft / Sway(φ) mm VZ084S Soft
Tire	SOREX 36 / deg
Wheel Offset Type	mm
Tire Diameter	mm
Chassis Height	4.5 mm
Used Optional parts	

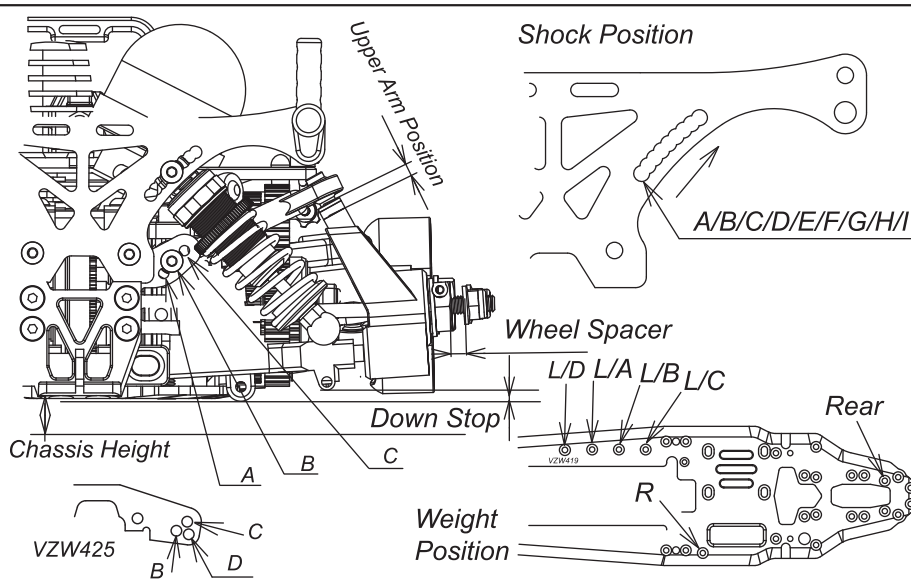

Gear	Total	Gear	Total	Gear	Total	Gear	Total	Gear	Total	Gear	Total
16	61	7.63	16	60	7.50	16	59	7.38	21	56	5.33
17	61	7.18	17	60	7.06	17	59	6.94	22	56	5.09
							59		23	56	4.87
									23	55	4.78
									23	54	4.69

Shock Oil	300 350 400 450 500 550 600 700 800
Diaphragm	N
Shock Piston	N
Spring	VZ073-4016
Spring Adjuster	mm
Shock Position	⊙/B/C/D/E/F/G/H/I
Wheel Spacer	0 mm
Upper Arm Position	mm 0 A / ⊙/C/D
Camber Angle	L 0 1 1.5 2 2.5 3 3.5 4 R 0 1 1.5 2 2.5 3 3.5 4
Toe Angle	3 deg
Rear Width	199 mm
Down Stop	-2 mm
Antiroll Bar	N mm
Tire	SOREX 36 / deg
Wheel Offset Type	mm
Tire Diameter	mm
Chassis Height	5 mm
Lower Arm Position	⊙(ZERO) ⊙(OUT 1mm) N / UP 0 mm
Weight	L(A/B/C/D)/R/Rear
Wheel Base	Short
Body-Shell	Kyosho SC430

Clutch Type	⊙ (VZW229)	Pinion Gear	⊙ 16 17 / ⊙ 21 22 23
Clutch Shoe	⊙ VZW229-03Y Yellow	Spur Gear	59 60 ⊙ / 54 55 ⊙
Clutch Weight	⊙ Other ( )	Drive Ratio	0mm Difference(24T Pully 387Belt) 2.5mm Difference(23T Pully 384Belt)
Clutch Spring	N (□1.7)/VZ⊙6 (□1.8)	Rear Diff Oil	4000
Clearance	0.25 mm	Main Chassis	N (VZ437) / VZW419
Adjust Nut	1.2 mm		

Memo アルミサ-ボセイバ- (R4) VZW404、カーボンフロントバンパープレートセット (R4) インナー ボンバーレッド