

Name	t.mizowaki	Temp	°C	Engine	OS 12TG	Muffler	OS φ6
Date	2014.12/28	Humidity	%	Head Clearance	mm	Fuel Type	NASA 25%
Track	R246	Traction	80 %	Plug No.	7	Radio	Futaba

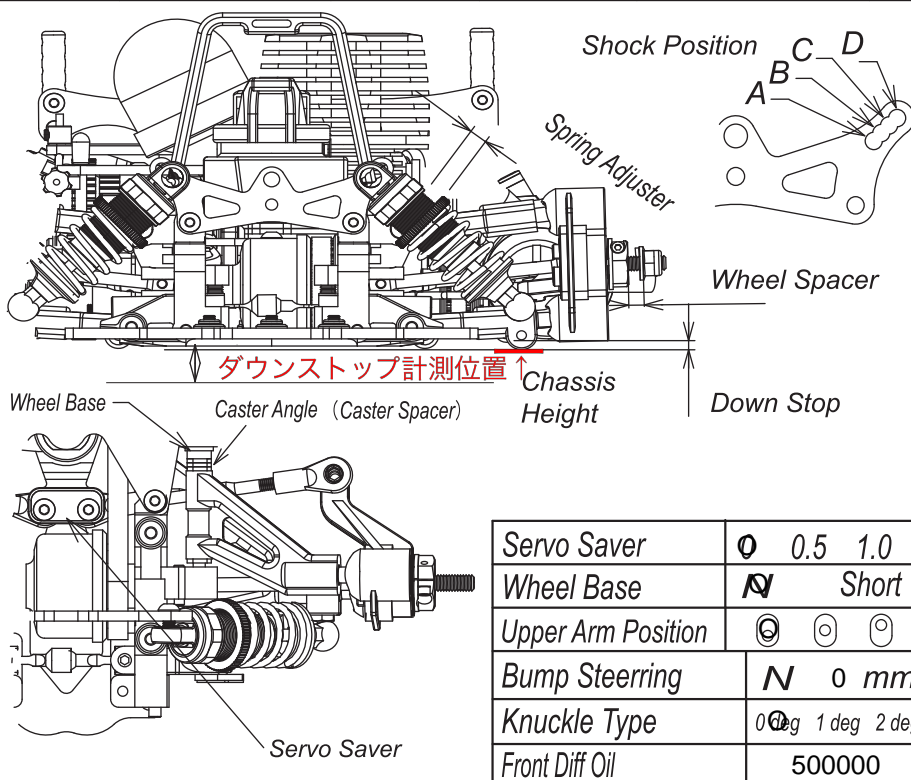

Servo Saver	0 0.5 1.0
Wheel Base	N Short
Upper Arm Position	0 1 2
Bump Steering	N 0 mm
Knuckle Type	0 deg 1 deg 2 deg
Front Diff Oil	50000

Shock Oil	300 350 400 450 500 550 600 700 800
Diaphragm	N
Shock Piston	N
Spring	TF027S-03
Spring Adjuster	mm
Shock Position	A B C D
Caster Angle (Spacer)	2 mm
Camber Angle (1G)	L 0 0.5 1 1.5 2 2.5 3 R 0 0.5 1 1.5 2 2.5 3
Toe Angle	-1 deg
Front Width	198 mm
Down Stop	-3 mm
Wheel Spacer	0 mm
Antiroll Bar	VZ084SS Super Soft / Sway(φ) mm VZ084S Soft
Tire	KC M / deg
Wheel Offset Type	mm
Tire Diameter	mm
Chassis Height	4.5 mm
Used Optional parts	

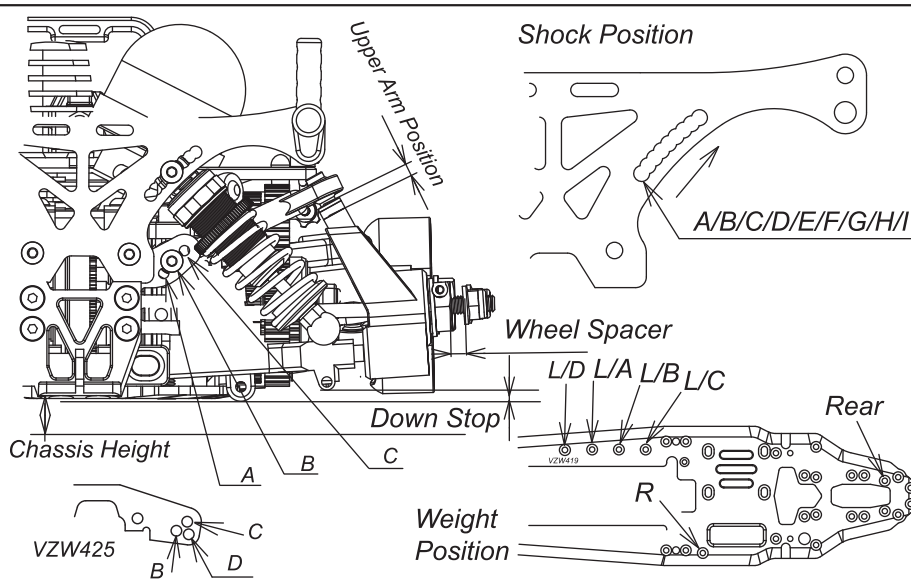

Gear	Total	Gear	Total	Gear	Total	Gear	Total	Gear	Total	Gear	Total
16	61	7.63	16	60	7.50	16	59	7.38	21	56	5.33
17	61	7.18	17	60	7.06	17	59	6.94	22	56	5.09
							59		23	56	4.87
									23	55	4.78
									23	54	4.69

Shock Oil	300 350 400 450 500 550 600 700 800
Diaphragm	N
Shock Piston	N
Spring	VZ073-4016
Spring Adjuster	mm
Shock Position	A/B/C/D/E/F/G/H/I
Wheel Spacer	0 mm
Upper Arm Position	mm 0 A / B / C / D
Camber Angle (1G)	L 0 0.5 1 1.5 2 2.5 3 3.5 4 R 0 0.5 1 1.5 2 2.5 3 3.5 4
Toe Angle	3 deg
Rear Width	199 mm
Down Stop	-2 mm
Antiroll Bar	N mm
Tire	KC M / deg
Wheel Offset Type	mm
Tire Diameter	mm
Chassis Height	5 mm

Clutch Type	0 (VZW229)	Pinion Gear	16 17 / 21 22 23
Clutch Shoe	N VZW229-03Y Yellow	Spur Gear	59 60 / 54 55
Clutch Weight	N Other ()	Drive Ratio	0mm Difference (24T Pully 387Belt) 2.5mm Difference (23T Pully 384Belt)
Clutch Spring	N (□1.7) / VZ06 (□1.8)	Rear Diff Oil	4000
Clearance	0.25 mm	Main Chassis	N (VZ437) / VZW419
Adjust Nut	1.2 mm	Body-Shell	Protoform P37-N

Memo アルミサ-ボセイバ- (R4) VZW404、カーボンフロントバンパープレートセット (R4)