

Name	Shimo	Temp	°C	Engine	OS 12XZ	Muffler	OS 1060
Date	2012/3/13	Humidity	%	Head Clearance	mm	Fuel Type	COSMO 16%
Track	BOSS SPED	Traction	%	Plug No.	RP6	Radio	Futaba 4PK S

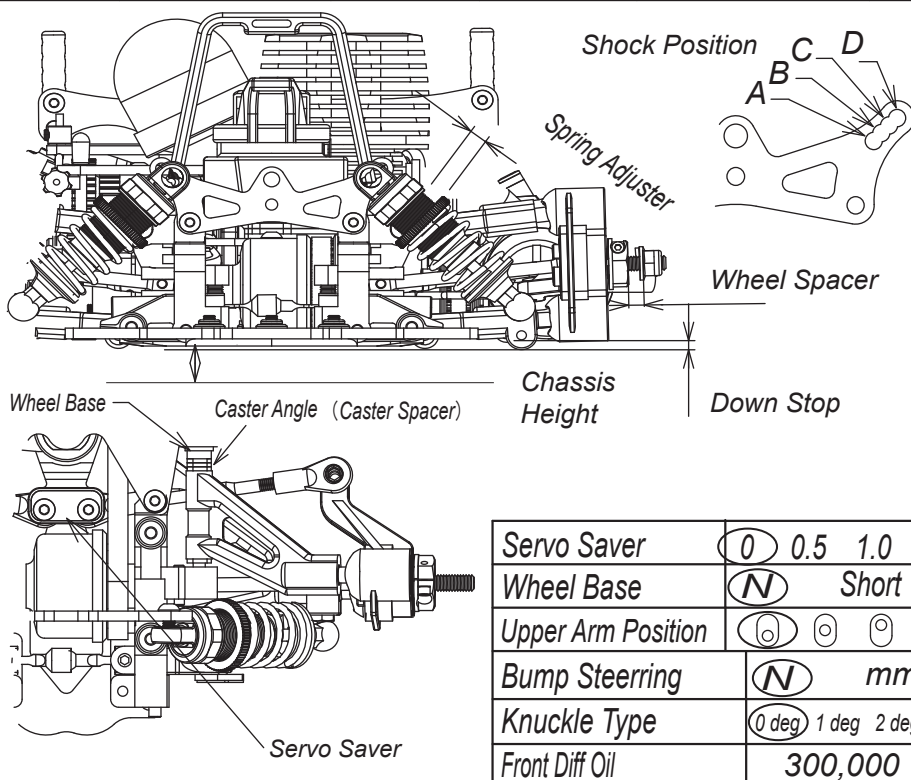

Shock Oil	300 350 400 450 500 550 600 700 800
Diaphragm	(N)
Shock Piston	(N) 試作 φ 1.2x3
Spring	VZW414-4017 イエロ-
Spring Adjuster	- mm
Shock Position	(A) B C D
Caster Angle _(Spacer)	3 mm
Camber Angle	L 0 0.5 1 1.5 2 2.5 3
(OG)IG	R 0 0.5 1 1.5 2 2.5 3
Toe Angle	-1.0 deg
Front Width	198 mm
Down Stop	-1 mm
Wheel Spacer	0 mm
Antiroll Bar	(Z084SS Super Soft) / Sway(φ) Bar mm
Tire	ZAC ZBB-812CCH
Wheel Offset Type	0 mm
Tire Diameter	φ 63 mm
Chassis Height	7 mm
Servo Saver	(0) 0.5 1.0
Wheel Base	(N) Short
Upper Arm Position	(0) (0) (0)
Bump Steering	(N) mm
Knuckle Type	(0 deg) 1 deg 2 deg
Front Diff Oil	300,000

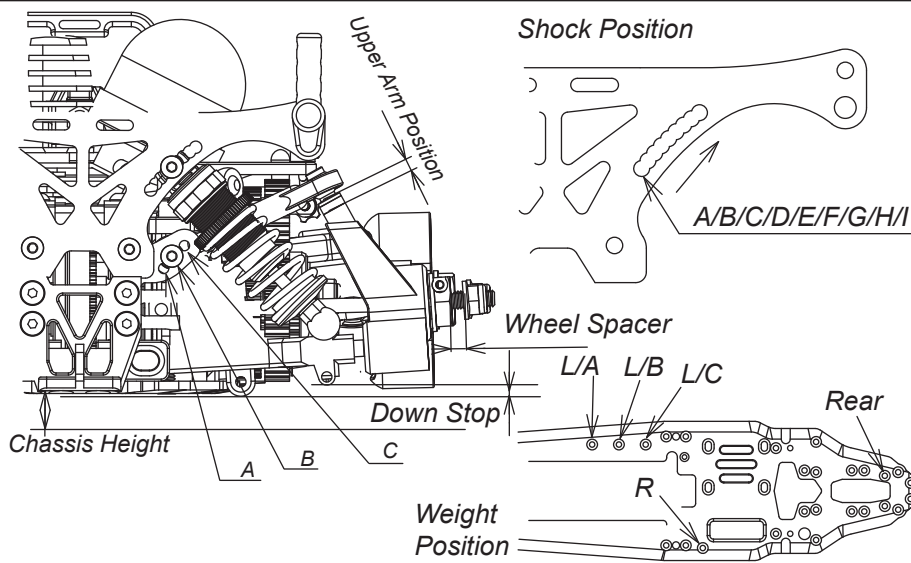

Shock Oil	300 350 400 450 500 550 600 700 800
Diaphragm	(N)
Shock Piston	(N)
Spring	VZW415-5017 イエロ-
Spring Adjuster	- mm
Shock Position	(A/B) C/D/E/F/G/H/I
Wheel Spacer	0 mm
Upper Arm Position	2 mm (A) (B) C
Camber Angle	L 0 0.5 1 1.5 2 2.5 3 3.5 4
(OG)IG	R 0 0.5 1 1.5 2 2.5 3 3.5 4
Toe Angle	3.0 deg
Rear Width	199.5 mm
Down Stop	0 mm
Antiroll Bar	(N) 2.0 mm
Tire	ZAC ZBB9121CH
Wheel Offset Type	0 mm
Tire Diameter	φ 65 mm
Chassis Height	8 mm

Gear	Total	Gear	Total	Gear	Total	Gear	Total	Gear	Total	Gear	Total
16	61	7.63	16	60	7.50	16	59	7.38	21	56	5.33
17	61	7.18	17	60	7.06	17	59	6.94	22	56	5.09
						59			23	56	4.87
									23	55	4.78
									23	54	4.69

Clutch Type	(N) VZW229	Pinion Gear	(15) 16 (17) (20) 21 (22) 23
Clutch Shoe	(Grey) Other ()	Spur Gear	59 60 (61) 54 (55) 56
Clutch Weight	(N) Other ()	Drive Ratio	0mm Difference(24T Pully 387Belt)
Clutch Spring	VZ446 φ1.8		(2.5mm Difference(23T Pully 384Belt))
Clearance	0.7 mm	Rear Diff Oil	50,000
Adjust Nut	1.5 mm	Battery Plate	N (Carbon) / Other ()
Lower Arm Position	(0) (ZERO) (0) (OUT 1mm)	Weight	(N) / UP mm
Wheel Base	(N) Short	Body-Shell	PF P37Nmm

Memo VZW419 SPメインシャシー使用

VZW411 カーボンバンパープレート使用 (4ヶ所固定)