

Name 宮崎和弘 Date 2008/11/30 Truck / City 相模湖プレジャーフォレスト SPL2 Event 綾瀬レース

Front Suspension

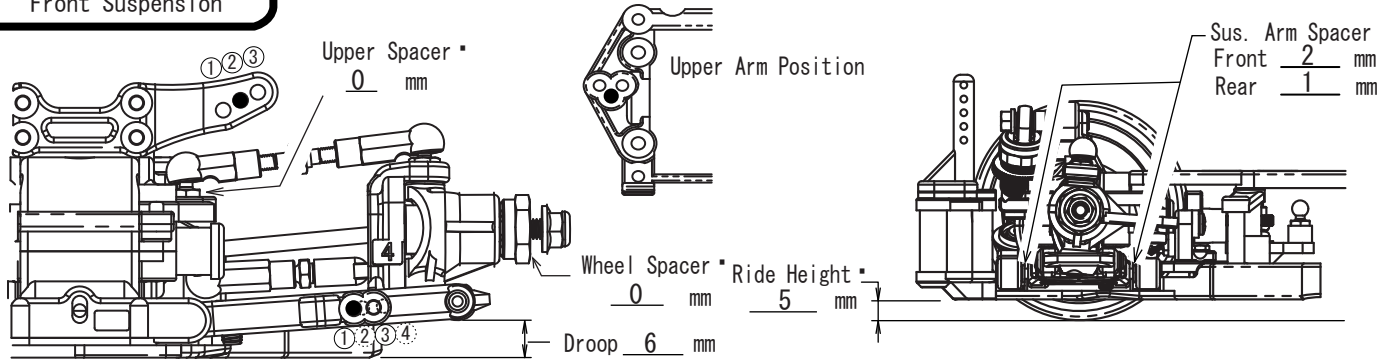

Sus. Holder Spacer

- | | | | |
|-------------------------------------|--|--|--|
| Front <input type="checkbox"/> | | Rear <input checked="" type="checkbox"/> | |
| <input type="checkbox"/> | | <input type="checkbox"/> | |
| <input checked="" type="checkbox"/> | | <input type="checkbox"/> | |
| <input type="checkbox"/> | | <input type="checkbox"/> | |

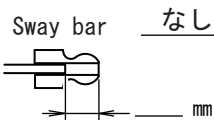

Toe Angle 0 °

Camber Angle 0.5 °

Front Diff.

- Spool
 Oneway
 Diff.

Rear Suspension

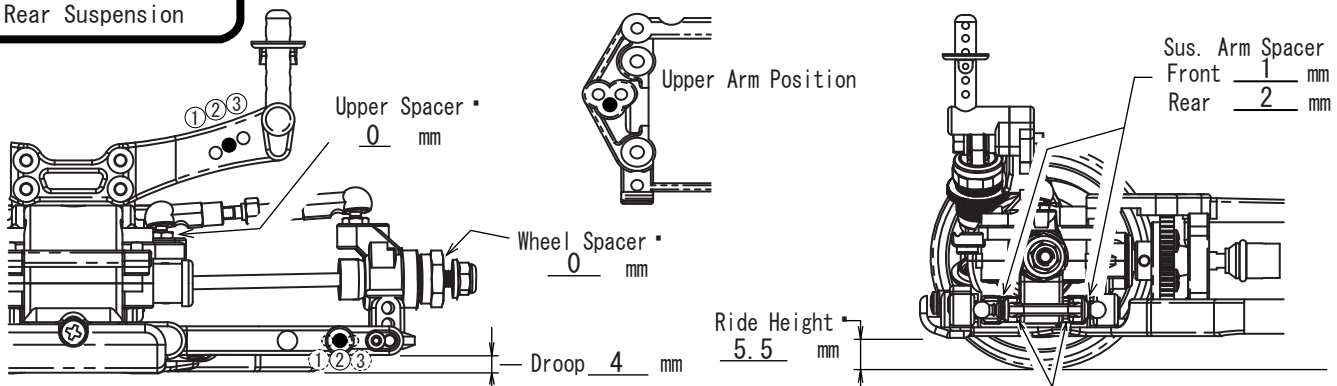

Sus. Holder Spacer

- | | | | |
|---|--|-------------------------------------|--|
| Front <input checked="" type="checkbox"/> | | Rear <input type="checkbox"/> | |
| <input type="checkbox"/> | | <input type="checkbox"/> | |
| <input type="checkbox"/> | | <input checked="" type="checkbox"/> | |
| <input type="checkbox"/> | | <input type="checkbox"/> | |

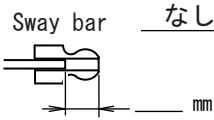

Toe Angle (3) °

Camber Angle 1 °

Hub Carrier Spacer
Front 2 mm
Rear 0 mm

Shock

	Front	Rear
Shock Piston	kit標準	kit標準
Shock Oil	# 350	# 350
Shock Spring	kit標準	kit標準
Diaphragm	kit標準	kit標準
Pressure Form	なし	なし
Shock Length	9.5 mm	10.5 mm

Normal W5189

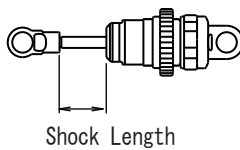

Weight Placement

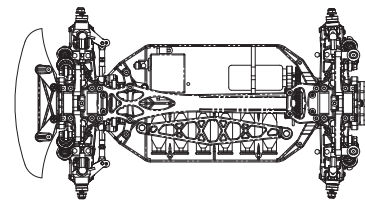

Tire

Tire	Comments
Sorex 32R	-----
Kyosho 36250H	-----
Kyosho VZH001BK	-----
Traction Compound	-----
1st: FX2	2nd: -

Others

Motor Orion Vortex Buggy (14T)
Pinion/Spur 33 / 68 Gear Ratio 5.15
Battery Orion Li-po 3400 ESC Orion Vortex
Body Kyosho NSX 2007

Truck Condition

- | | |
|---|---|
| <input checked="" type="checkbox"/> Smooth | <input checked="" type="checkbox"/> Asphalt |
| <input type="checkbox"/> Bumpy | <input type="checkbox"/> Concrete |
| <input type="checkbox"/> Low Traction | <input type="checkbox"/> Carpet |
| <input checked="" type="checkbox"/> Med. Traction | <input type="checkbox"/> Indoor |
| <input type="checkbox"/> High Traction | <input checked="" type="checkbox"/> Outdoor |

Comment :
