

Name
Takashi Hamasaki

Date
2019/12/24

Truck/City
Green Park Speed Way

Event

Front

Shock Position:

FAW222

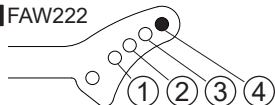

Camber Angle: -1.5°

- 0 +

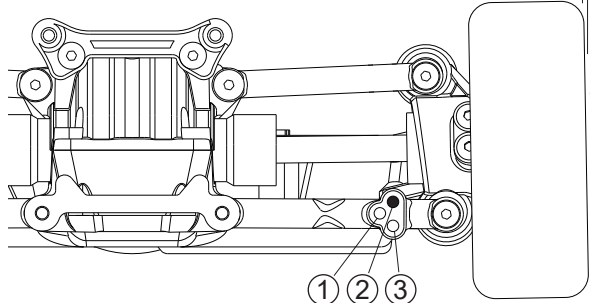

Normal
 FAW205

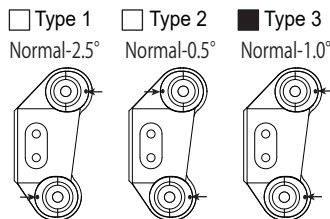

Upper Arm Spacer

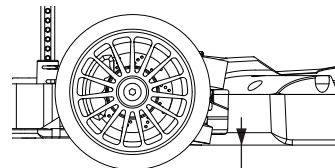
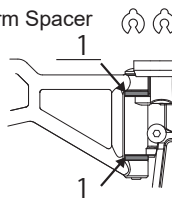

Ride Height: 8.0 mm

Tie Rod:

Normal
 Adjustable

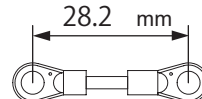

FAW208
Sway Bar: S M H



Front Diff.:

Spool
 Oneway
 Diff.
 4 Bevel
Diff. Oil
60000

Rear

Shock Position:

FAW223

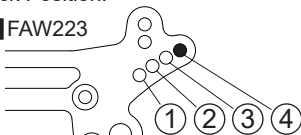

Camber Angle: -2.0°

- 0 +

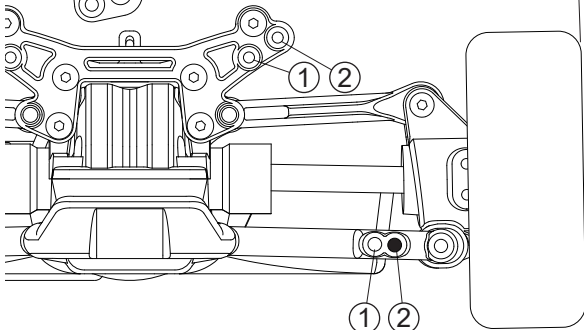

Normal
 FAW206

Upper Arm Position:

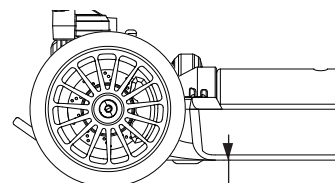
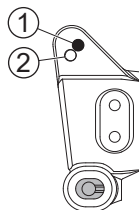

Ride Height: 8.0 mm

FAW208
Sway Bar: S M H



Rear Diff.:

4 Bevel
Diff. Oil
3000

Shock

Front

Rear

Standard

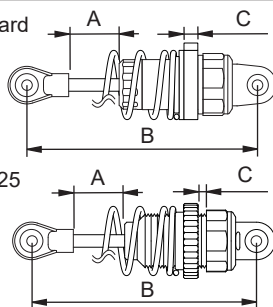

Shock Piston



Shock Oil

400

400

Shock Spring

W BL Y R

W BL Y R

Shock Length A

55 mm

56 mm

Shock Length B

13.5 mm

14.5 mm

Spring Spacer C

4.5 mm

5.5 mm

FAW225

Chassis Width

190mm
 200mm

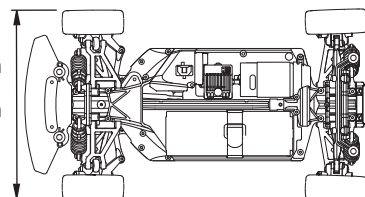

Tire

Tire KC Slick S

Inner Sponge Bomber Red

Wheel 15 Spoke Black

Traction Compound 1st: Mighty Blue 2nd:

Comments

Others

Motor Le•Mans 240S 19.5T (Timing : Max)

Pinion/Spur 35T / 68T Input/Ring 13T / 40T

Battery Gensace LiPo 4000 ESC Le•Mans 240S ESC

Body AUDI R8 Wing Normal / + 3°

Truck Condition

Smooth
 Bumpy
 Low Truaction
 Med. Truaction
 High Truaction

Asphalt
 Concrete
 Carpet
 Indoor
 Outdoor

Comments :

