

Name _____

Date _____ / _____ / _____

Truck/City _____

Event _____

Front

Shock Position:

FAW222

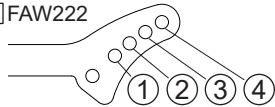

Camber Angle: _____ °

- 0 +

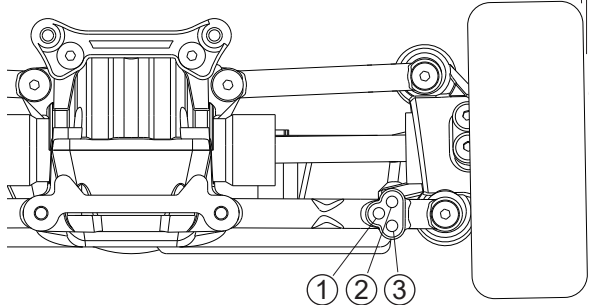

Normal
 FAW205

Type 1
Normal-2.5°

Type 2
Normal-0.5°

Type 3
Normal-1.0°

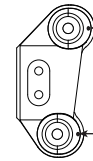
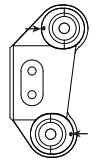
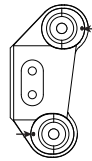

Upper Arm Spacer

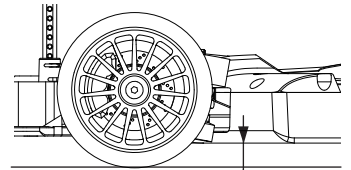
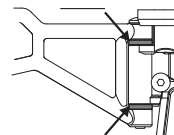

Ride Height: _____ mm

Tie Rod:

Normal
 Adjustable

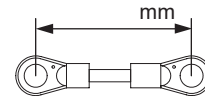

FAW208

Sway Bar: S M H

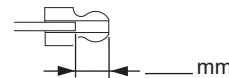

Front Diff.:

Spool
 Oneway
 Diff.
 4 Bevel
Diff. Oil _____ #

Rear

Shock Position:

FAW223

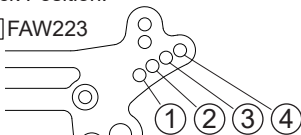

Camber Angle: _____ °

- 0 +

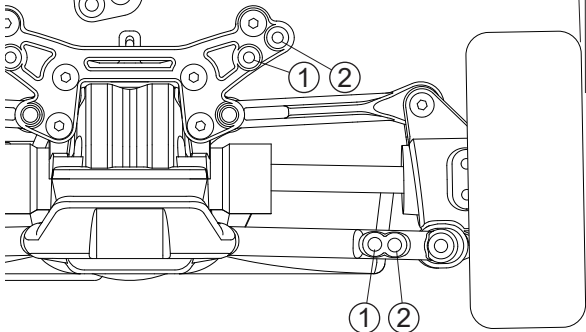

Normal
 FAW206

Upper Arm Position:

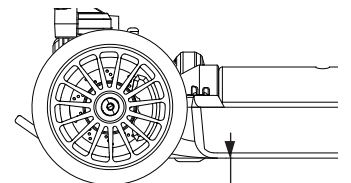

Ride Height: _____ mm

FAW208

Sway Bar: S M H

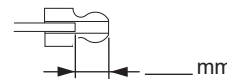

Rear Diff.:

4 Bevel
Diff. Oil _____ #

Shock

Front

Rear

Standard

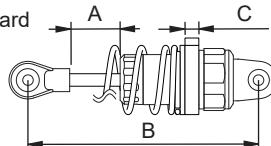

FAW225

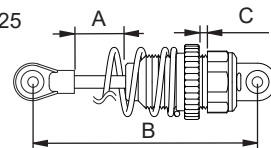

Chassis Width

190mm

200mm

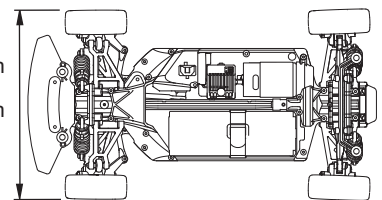

Shock Piston



Shock Oil # _____

Shock Spring

W BL Y R

W BL Y R

Shock Length A _____ mm

_____ mm

Shock Length B _____ mm

_____ mm

Spring Spacer C _____ mm

_____ mm

Tire

Tire _____

Inner Sponge _____

Wheel _____

Traction Compound 1st: _____ 2nd: _____

Comments _____

Others

Motor _____ (Timing: _____)

Pinion/Spur _____ / 68T Input/Ring 13T / 40T

Battery _____ ESC _____

Body _____ Wing _____ / + °

Truck Condition

Smooth

Bumpy

Low Truaction

Med. Truaction

High Truaction

Asphalt

Concrete

Carpet

Indoor

Outdoor

Comments : _____