

Name  
宮崎和弘

Date

Truck / City  
京商サーキット

Event

### Front Suspension

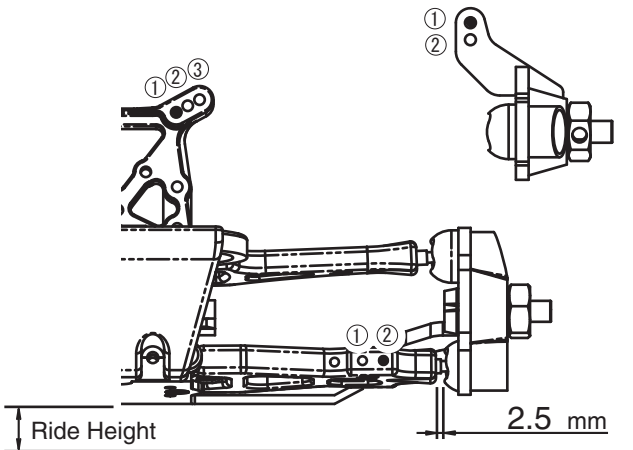

Ride Height 2.5 mm

Toe  In  Out 0 ° Ride Height 9.0 mm

Camber 2 ° Sway Bar φ2.3

### Rear Suspension

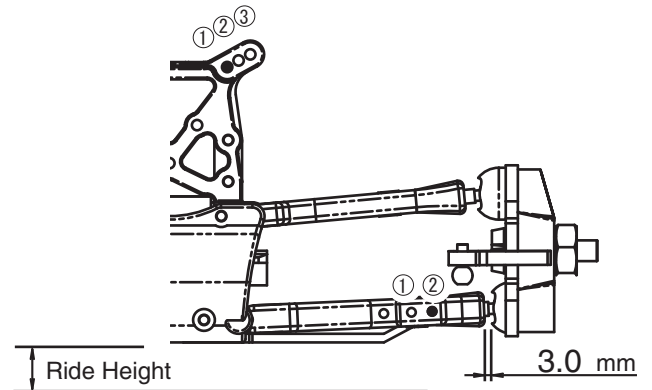

Ride Height 3.0 mm

Toe  In  Out 2.0 ° Ride Height 10.0 mm

Camber 2 ° Sway Bar φ2.3

### Shock

kit / readysset  
 TRW105  
 W5304V

	Shock Piston	<u>φ 1.3x2穴 IFW19</u>
	Shock Oil	<u># 500</u>
	Shock Spring	<u>TRW155-6514</u>
	Shock Length	<u>B : 95 mm</u>
	Spring Tension	<u>mm</u>

	Shock Piston	<u>φ 1.3x2穴 IFW19</u>
	Shock Oil	<u># 500</u>
	Shock Spring	<u>TRW155-6514</u>
	Shock Length	<u>B : 95 mm</u>
	Spring Tension	<u>mm</u>

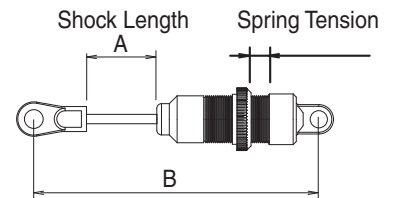

### Diff

Front Diff.	# <u>100,000</u>	<input type="checkbox"/> 2bevel <input checked="" type="checkbox"/> 4bevel
Center Diff.	# <u>2 speed</u>	<input type="checkbox"/> 2bevel <input type="checkbox"/> 4bevel
Rear Diff.	# <u>5,000</u>	<input type="checkbox"/> 2bevel <input checked="" type="checkbox"/> 4bevel

### Engine

Engine GXR-18 SP

Muffler TRW154

Clutch bell / Spur 13 / 16 - 43 / 46

Clutch IFW339

Clutch Spring φ 1.00(IFW53) x2 , φ 1.10(IFW53H) x1

### Tire

Front Tire	<u>TRT122</u>	Compound	<u>                    </u>
Rear Tire	<u>TRT122</u>		
Front Inserts	<u>proline クローストセル</u>		<u>612205</u>
Rear Inserts	<u>proline クローストセル</u>		<u>612205</u>
Wheel	<u>TRH121</u>		

### Truck Condition

<input type="checkbox"/> Smooth	<input type="checkbox"/> Wet	<input type="checkbox"/> Blue Groove
<input type="checkbox"/> Bumpy	<input type="checkbox"/> Dry	<input type="checkbox"/> Clay
<input type="checkbox"/> Low Truaction	<input type="checkbox"/> Sandy	<input type="checkbox"/> Dusty
<input type="checkbox"/> Med. Truaction	<input type="checkbox"/> Soft Dirt	<input type="checkbox"/> Asphalt
<input type="checkbox"/> Higt Truaction	<input type="checkbox"/> Grass	<input type="checkbox"/> Other

### Option Parts

- ・ R246メインシャーシ
- ・ 3pcsフライホイ

### Comment :

ボディ : シトロエン  
ダンパーにはダイヤフラムを使用。  
タイヤインナーは裏返して使用。