

Name _____

Date _____

Truck / City _____

Event _____

Front Suspension

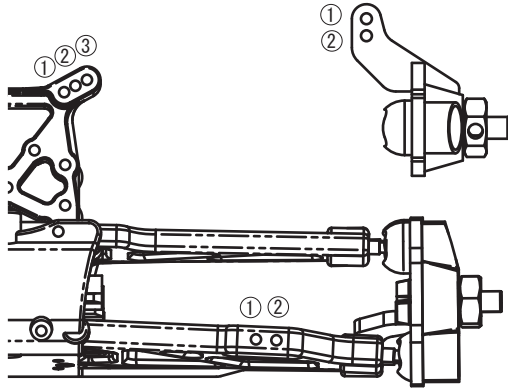

Toe In Out _____° Ride Height _____ mm
 Camber _____°

Rear Suspension

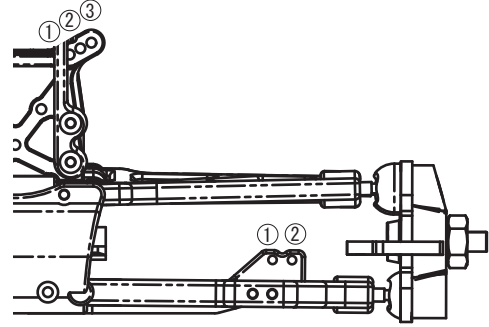

Toe In Out _____° Ride Height _____ mm
 Camber _____°

Shock

	Front	Rear
Shock Piston	_____ - _____	_____ - _____
Shock Oil	# _____	# _____
Shock Spring	_____	_____
Shock Length	_____ mm	_____ mm

Shock Length

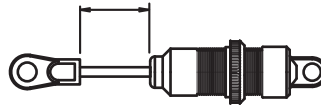

Diff

Front Diff.	# _____	<input type="checkbox"/> 2bevel	<input type="checkbox"/> 4bevel
Center Diff.	# _____	<input type="checkbox"/> 2bevel	<input type="checkbox"/> 4bevel
Rear Diff.	# _____	<input type="checkbox"/> 2bevel	<input type="checkbox"/> 4bevel

Engine

Engine _____
 Clutch bell/Spur _____ / _____
 Clutch _____
 Clutch Spring _____

Tire

	Compound
Front Tire	_____
Rear Tire	_____
Front Inserts	_____
Rear Inserts	_____
Wheel	_____

Truck Condition

<input type="checkbox"/> Smooth	<input type="checkbox"/> Wet	<input type="checkbox"/> Blue Groove
<input type="checkbox"/> Bumpy	<input type="checkbox"/> Dry	<input type="checkbox"/> Clay
<input type="checkbox"/> Low Truaction	<input type="checkbox"/> Sandy	<input type="checkbox"/> Dusty
<input type="checkbox"/> Med. Truaction	<input type="checkbox"/> Soft Dirt	<input type="checkbox"/> Other
<input type="checkbox"/> Higt Truaction	<input type="checkbox"/> Grass	

Option Parts

Comment : _____

