

This guide explains how to prepare the model & transmitter for flight and how to reset the gyro, and also provides basic troubleshooting and explanation of throttle control for beginners to experts. For other instructions, please refer to the manual included with the model.

● Contents



1 Prepare Radio

1 Insert batteries into transmitter (Page 12)



AA alkaline batteries x 4

▶ Oxiride batteries cannot be used.

(Page 12)

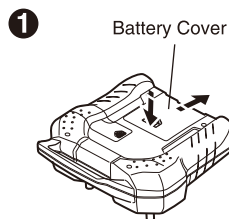

▶ + - Insert batteries correctly

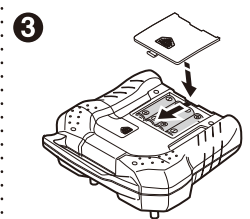
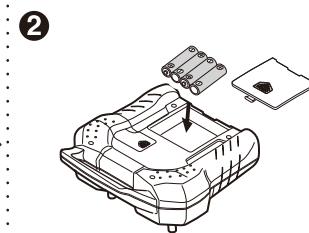

2 To change to Mode 2 (Page 14)

(Page 14)

- 1** While pushing the right stick on the transmitter, switch power ON.
- 2** Battery level indicator flashes for 3 seconds.
- 3** When LCD screen shows the mode, change is complete.
- 4** Input the trim values.

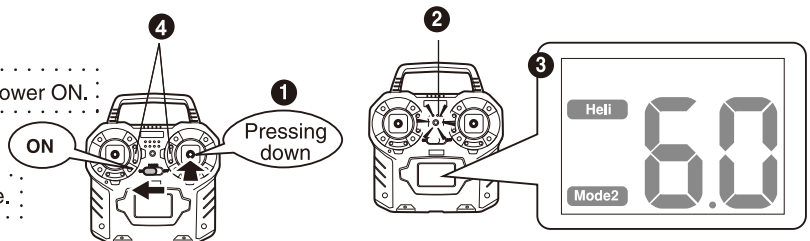

▶ Elevator and throttle trim values do not change.

- Check the trim values and set throttle trim to 0 and set elevator trim to the value it had when shipped.

● The model is set to Mode 1 at time of shipment.

2 Prepare Helicopter 1

1 Attaching the Training Safety Bar (Page 12)

(Page 12)

▶ Until you get used to the throttle control, attaching the training safety bar is recommended for all users, from beginners to experts.

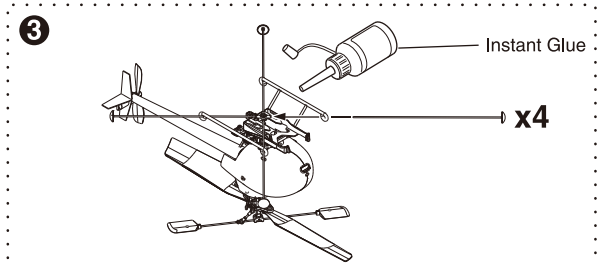
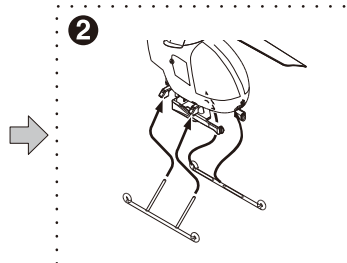
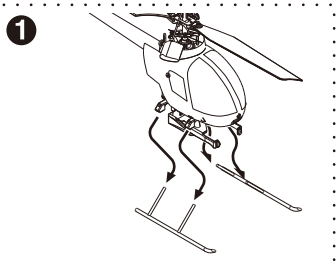

2

Prepare Helicopter 2

2 Charge the 3.7V-150mAh Lithium Polymer battery (Page 13)

1

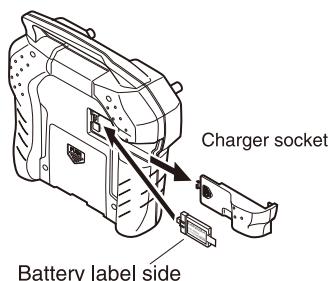

2

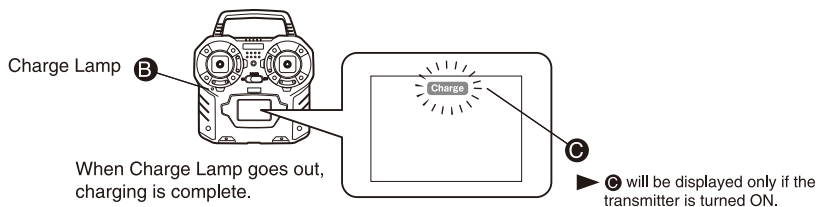

▶ Battery can be charged whether the transmitter is ON or OFF.

▶ The battery will not charge if the transmitter voltage is less than 5.0V or the 3.7V-150mAh lithium polymer battery is still more than 80% charged. (Recharge after use).

3

Prepare Flight

● Switch transmitter ON and connect the battery. (Page 16)

1



2

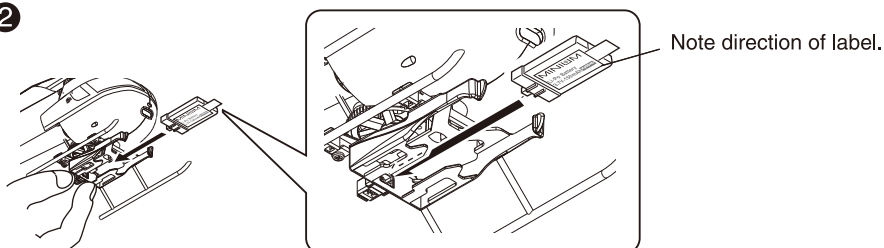

- About 7 seconds after battery has been connected, the gyro detects neutral and helicopter control and flight are possible. (Page 34).
- Try to get the helicopter ready for takeoff within the 7 seconds.

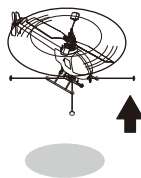

▶ Moving the helicopter while the gyro is finding neutral can cause the rudder neutral to deviate. In this case, follow the steps below in 4 and reset the gyro.

4

Reset the gyro

● In the following cases, reset the gyro.

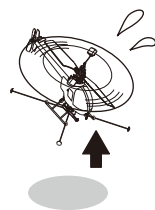

If helicopter moves while finding neutral

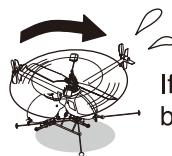

If tail is spinning before takeoff.

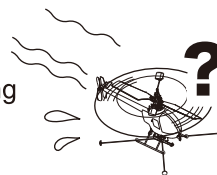

If rudder trim slips during flight.

● Resetting the gyro

1 Reset the helicopter on a flat surface

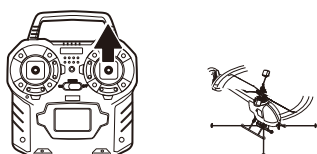

Lift the throttle stick slightly to slowly rotate the main and tail rotors.

2

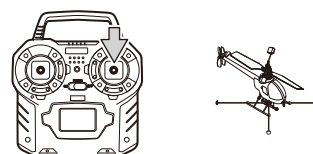

Move throttle stick to neutral to stop rotation of main and tail rotors. After 3 seconds, the gyro's neutral will be reset.



If helicopter doesn't seem to be functioning properly.

► This section covers basic troubleshooting.
For more comprehensive troubleshooting, parts replacement and maintenance,
please refer to P39~50 of the main instruction manual.

1 Oscillation

Helicopter rocks back and forth and side to side

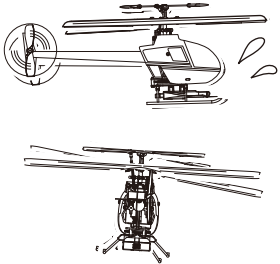

(Page 46)

► Loosening or tightening the screws holding the main rotors can reduce oscillation.

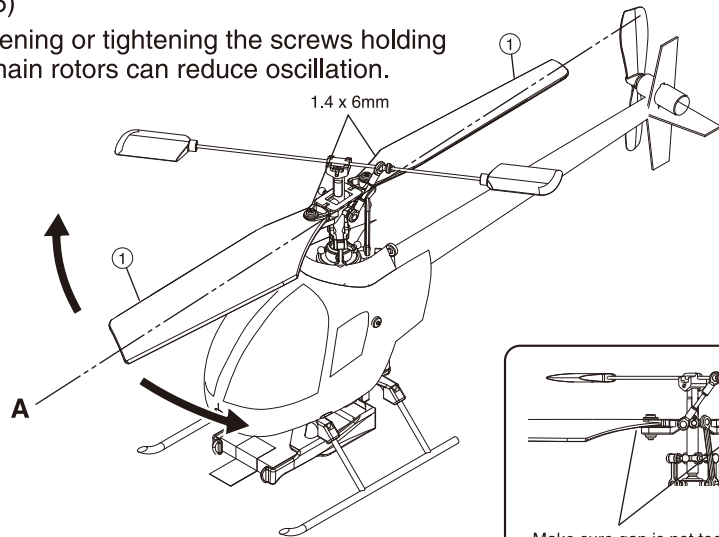

Tighten 1.4 x 6mm screws so ① can move smoothly.

If both rotors are unbalanced, there may be some vibration in the direction of the elevator. If balance is not easy to adjust and there is vibration in the direction of the elevator, firmly fix ① so they are in a straight line.

► In the event of a crash, the main mast may bend and cause vibration or oscillation.

2 Helicopter suddenly loses height.

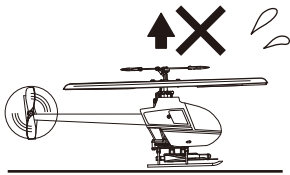

(Page 40)

► The mixing lever may be facing in the wrong direction as a result of the shock from a crash. Lift the stabilizer bar up and rotate the lever to the left to return it to its proper position.

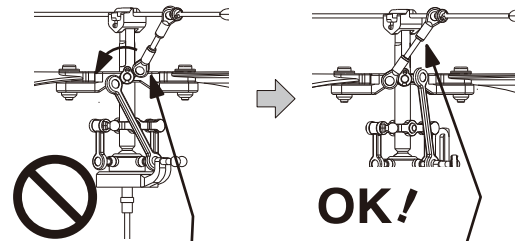
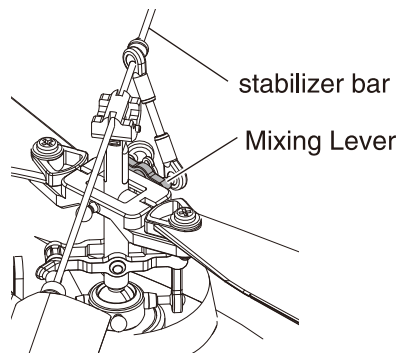

It is not normal for the rod to drop to vertical.

Angle of rod is normal.

► In addition to motor life, motor performance can be affected by damage to the motor brushes in a crash. (In this case, main motor replacement is required).

(Page 44)

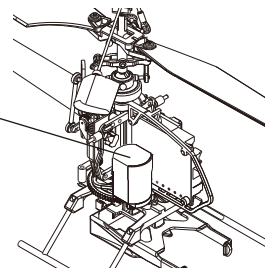

3 If tail is spinning before takeoff.

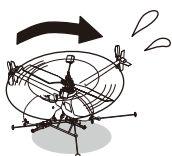

► Reset the gyro (→④)

► If tail continues to spin after gyro has been reset, the tail motor may be worn out. (In this situation, replace the tail motor).

(Page 45)

1 For first time users (Page 35)

► For first time users, set the throttle trim to -3 for mild throttle control. After 1-2 minutes, the helicopter's ability to ascend will deteriorate. When this occurs, move the throttle trim up 1 value at a time.

● Fully charged battery

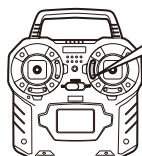

Push lower trim 3 times.



● Ascends weakly.

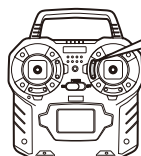

Push upper trim once at a time.

► Moving the throttle trim above +1 has no further effect. (Page 35)

2 For Experts

► Gradually increase main rotor speed until the helicopter starts to lean to the left. Then while increasing the throttle further, use the right aileron slightly and lift off and hold steady at about 50cm. (Use throttle control so the helicopter hangs in the air.)

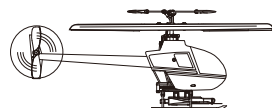

approx. 50cm

► Why 50cm?

The characteristics of fixed pitch mean main rotor speed governs the helicopter's ascent and descent. Even when trying to keep the helicopter low and stable for indoor flight, the helicopter can easily rise to about 1m. Practice throttle control at a low altitude until you get an improved sense of control.

► Reduce throttle input slowly when hovering or landing.

As the throttle sticks on the transmitter have springs, always remember to reduce throttle slowly to maintain stability.

After mastering the ability to maintain height, if you can move the ailerons left or right while maintaining height, you can make banking turns.

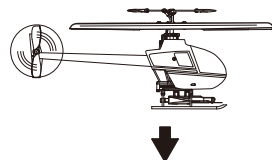

- After flight, remove the 3.7V 150mAh lithium polymer battery and switch the transmitter OFF.
- Transmitter uses standby power even when switched off. Remove batteries when not in use.